

# BALTIC SNG AHSPM USER MANUEL

## 1. Foreword

This guide is prepared for Baltic SNG AHSPM. The details below are examined in general.

-How the refrigerator will be used -Technical Details -Installation and Assembling -  
Infos and suggestions for the users -Care operations

Producer company does not have any responsibilities about the situations below. -  
Wrong usage of the refrigerator -Wrong assembling -Electrical Effects -Not doing  
the periodical cares -Changes of Operation -Not using the original spare parts -  
Ignoring the given infos

P.S. : Applications about electricity are dangerous for your life. Anyone who uses  
the refrigerator must read this guide.

## 2.Introduction



Baltic SNG AHSPM is a half glass door, frozen food combi case. It's condensing unit is designed as a remote. With its wide display area and loading capacity, it is suitable for normal to and larger stores.

Food such as frozen meat, fish and ice-cream can be displayed in the cabinet. The cabinet has an electrical defrost

Run case module are 2500 mm and 3750 mm long.

### 3. Technical Details

	<b>TECHNICAL DATA SHEET - BALTIC AHSPM</b>
---	--

<b>TECHNICAL DETAILS</b>	<b>2500</b>	<b>3750</b>
--------------------------	-------------	-------------

Refrigeration Load		
Case Temp (°C)	-21/-23	
Evap Temp (°C)	-35	
Duty (kW)	1,69	2,54
Expansion Valve (R744)	AKVH 10-1	AKVH 10-2
Evap. Surface (m <sup>2</sup> )	32,85	51,39
Evap. Internal Pipe Volume (dm <sup>3</sup> )	5,30	8,22
Working / Test Pressure	60 / 66 bar	
Pipe Size - Suction	10 mm	12 mm
Pipe Size - Liquid	10 mm	10 mm
Pipe Size - Drain	28 mm	
Cubic Capacity (dm <sup>3</sup> )	1643	2464
Display Area	6,05	9,08

Defrost Details	
Defrost Type	Electric
Duration (minutes)	1 x 60 min.
Termination	Temp. (+10 C)

Heaters		
Evaporator (Coil)	4 x 800W	4 x 1200W
Frame (Schott Termofrost)	330 W	509 W
Doors (Schott Termofrost)	4 x 66W	6 x 66W
Front Glass	124W	2 x 94W
Side Glass	-	-
End Walls	-	-
Body	3 x 50W	3 x 75W
Water Drain	16W	16W
Air Return	200W	2 x 150W
Air Intake	30W	45W

Electrical / Fans			
Supply	230 V / 50 Hz		
Lighting LED	on frame (Nualight porto 600 cool white)	5 x 14W	7 x 14W
	on wall (Nualight centro 500 5100K)	2 x 26W	3 x 26W
Evaporator Fan Blowing	EBM M1G 055-BD91	2 x 7W - 1700 RPM	3 x 7W - 1700 RPM
	ELCO ECM HC 12-10-2	( AO 154mm/28° )	( AO 154mm/28° )
Evaporator Fan Suction	EBM M1G 055-BD91	2 x 7W - 1200 RPM	3 x 7W - 1200 RPM
	ELCO ECM HC 12-10-2	( A 154mm/28° )	( A 154mm/28° )

Design Conditions					
Temp (°C)	25	Humidity (%)	60	Cross Draft Air Speed (m/s)	0,2

Air Flow Info	
Air Speed on honeycomb	0,5 m/s at ambient conditions

	TECHNICAL DOCUMENTATION	CHAPTER REVISION STATUS					
		ORD.	DATE	CHANGE ORDER	ORD.	DATE	CHANGE ORDER
PRODUCT	Baltic AHSPM	A	04.04.14	U.GUDUCU	D		
DATE of 1st ISSUE	04.02.2014	B			E		
ORDER	ULAS GÜDÜCÜ	C			F		



**TECHNICAL DATA SHEET - BALTIC AHSPM**

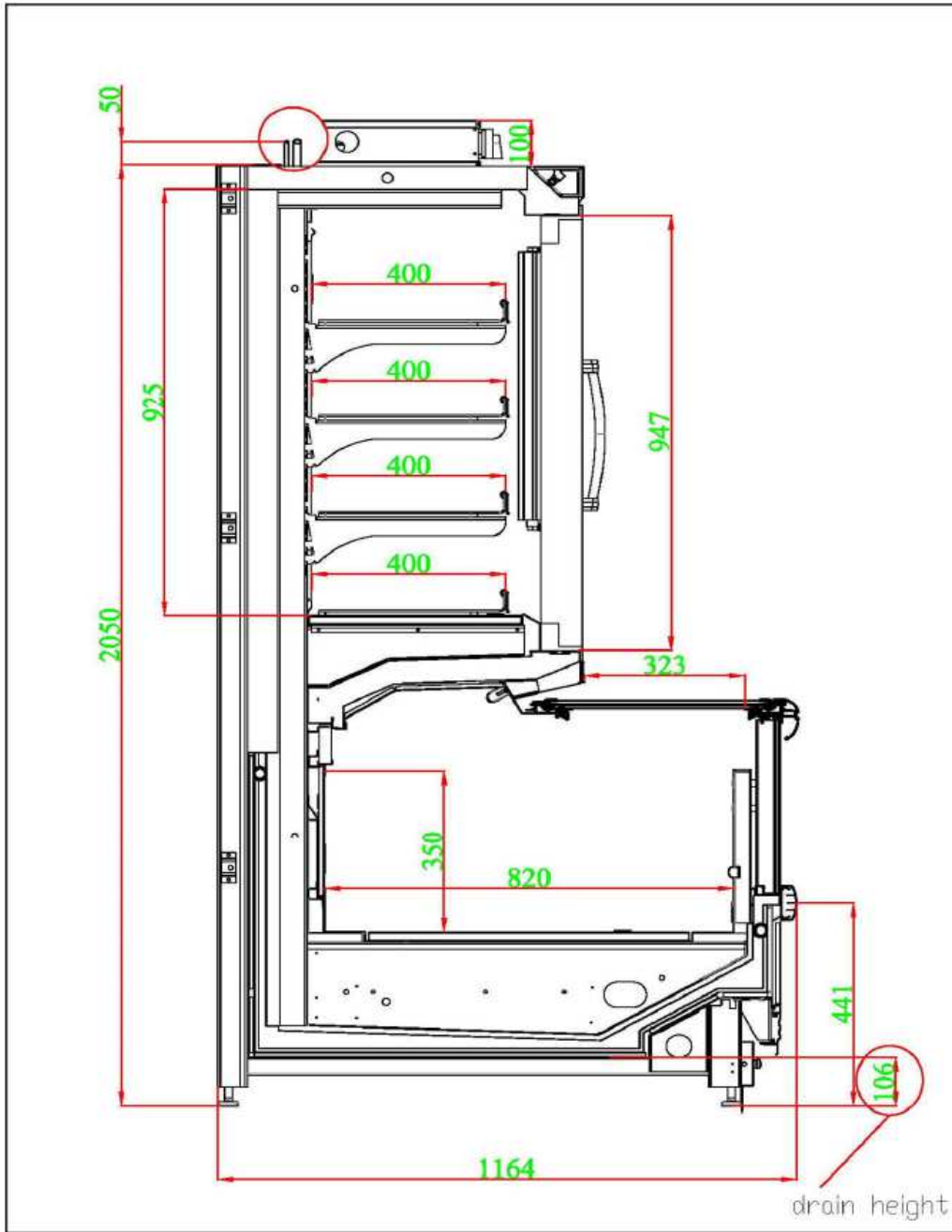

	TECHNICAL DOCUMENTATION	CHAPTER REVISION STATUS					
		ORD.	DATE	CHANGE ORDER	ORD.	DATE	CHANGE ORDER
PRODUCT	Baltic AHSPM	A	04.04.14	U.GÖDÜCÜ	D		
DATE of 1st ISSUE	04.02.2014	B			E		
ORDER	ULAS GÖDÜCÜ	C			F		



TECHNICAL DATA SHEET - BALTIC AHSPM

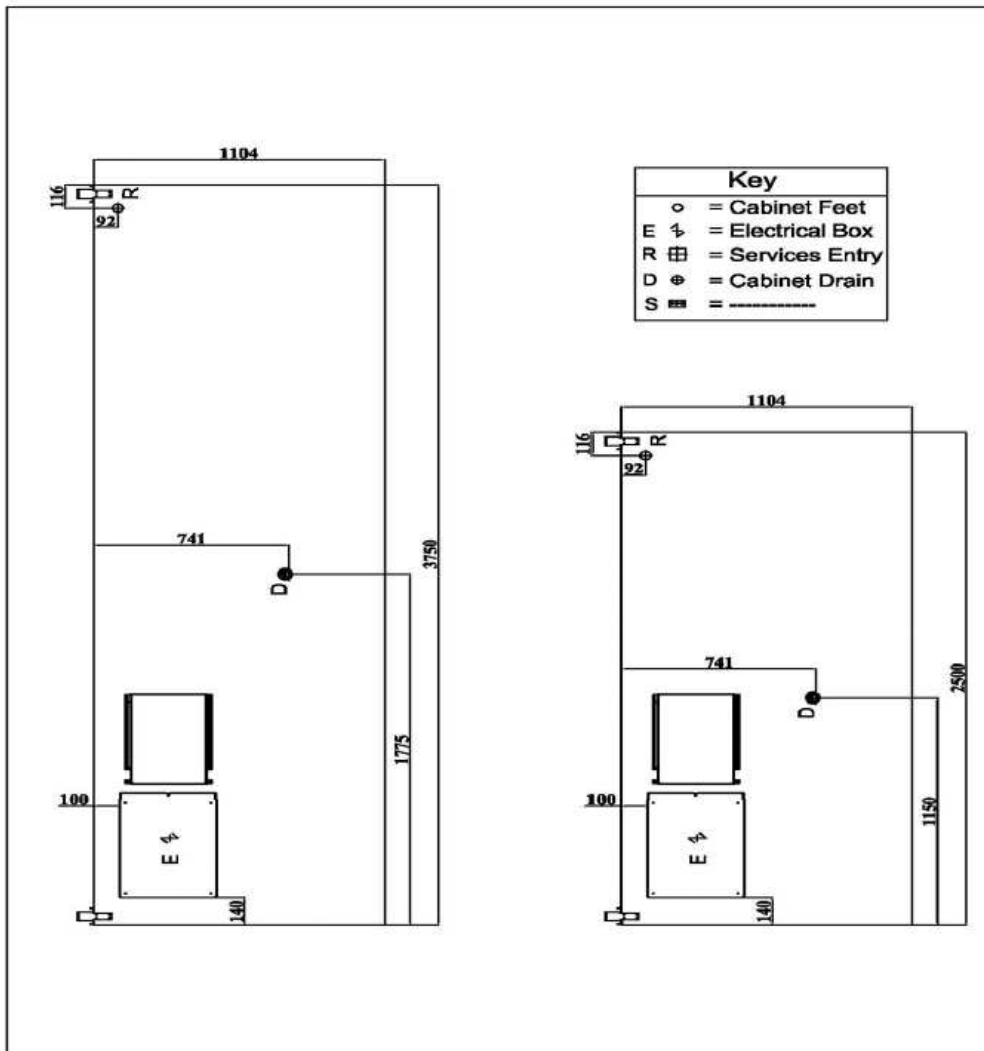

	TECHNICAL DOCUMENTATION	CHAPTER REVISION STATUS					
		ORD.	DATE	CHANGE ORDER	ORD.	DATE	CHANGE ORDER
PRODUCT	Baltic AHSPM	A			D		
DATE of 1st ISSUE	04.02.2014	B			E		
ORDER	ULAS GÜDÜCÜ	C			F		

	TDA CALCULATION - BALTIC AHSPM
---	--------------------------------

MODUL	Ho	Loh	Tgh	Hg	Lgh	Vo	Lov	Vgt	Tgvt	Lgvt	Vgb	Tgvb	Lgvb	TDA
2500	0,32	2,50	1	0	2,50	0	2,50	0,81	0,64	2,13	0,22	0,73	2,43	2,29
3750	0,32	3,75	1	0	3,75	0	3,75	0,81	0,64	3,19	0,22	0,73	3,61	3,44

TDA = (Ho\*Loh)+(Tgh\*Hg\*Lgh)+(Vo\*Lov)+(Vg\*Tgv\*Lgv) prEN ISO 23953-2

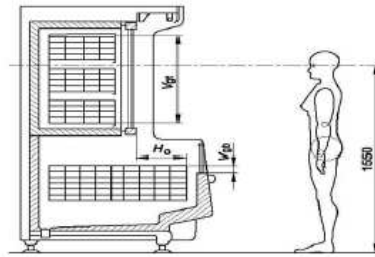

\*Tgvt value according to ISO 9050

	TECHNICAL DOCUMENTATION	CHAPTER REVISION STATUS					
		ORD.	DATE	CHANGE ORDER	ORD.	DATE	CHANGE ORDER
PRODUCT	Baltic AHSPM	A			D		
DATE of 1st ISSUE	04.02.2014	B			E		
ORDER	ULAS GÖDOĞU	C			F		

## 4. Norms and Certificates

The approved certificates of norms and refrigerators that are using as reference; EN 60204-1; EN 61439-1; EN 61439-2

### ENVIRONMENTAL CLIMATIC ATMOSPHERE (EN 23953-2)

This refrigerator is tested as to atmosphere heat class 3.

Class	Dry Air Temperature	Relative Humidity	Dew Point
1	16 °C	%80	12 °C
2	22 °C	%65	15 °C
3	25 °C	%60	17 °C
4	30 °C	%55	20 °C
5	40 °C	%40	24 °C
6	27 °C	%70	21 °C

The directives that the refrigerator suits EEC 73/23 , EEC 98/37



## 5. Warning and definition stickers on the case

Fragile Sticker



High Voltage Sticker



Product Description

		AHMET YASAR REFRIGERATION Mah. S. Cak. No:5 Karmirbası Organize San. Bölgesi/İzmir-35030 Türkiye Tel: +90 232 8717001 www.ahmetyasar.com.tr	CE
PRODUCT	: CABINET	FLNG	: 120 (lit)
MODEL	: BALTIC SNG-AHSP 2500H	LIGHTING	: 40.5 (lit)
PRODUCT NUMBER	: 60335-1-000001	DEFROST HEATER	: 3200 (Watt)
PRODUCTION DATE	: 2016-02-12	AIR RETURN HEATER	: 220 (lit)
CLASS	: B	WATER CHAMBER HEATER	: 18 (lit)
TEMPERATURE RANGE	: -18 to +24 °C	HEATER ON GLASS	: 106.5 (lit)
REFRIGERANT	: R600a	MAX POWER CONSUMPTION	: 395.2 (lit)
TEST PRESSURE	: 12 (bar)		
WORKING PRESSURE	: 6 (bar)		
DEREGULATIVE	: 2006 / 16 / EC - 2004 / 100 / EC		
STANDARD	: EN 60335-1-EN 60335-2-24		

Step Sticker

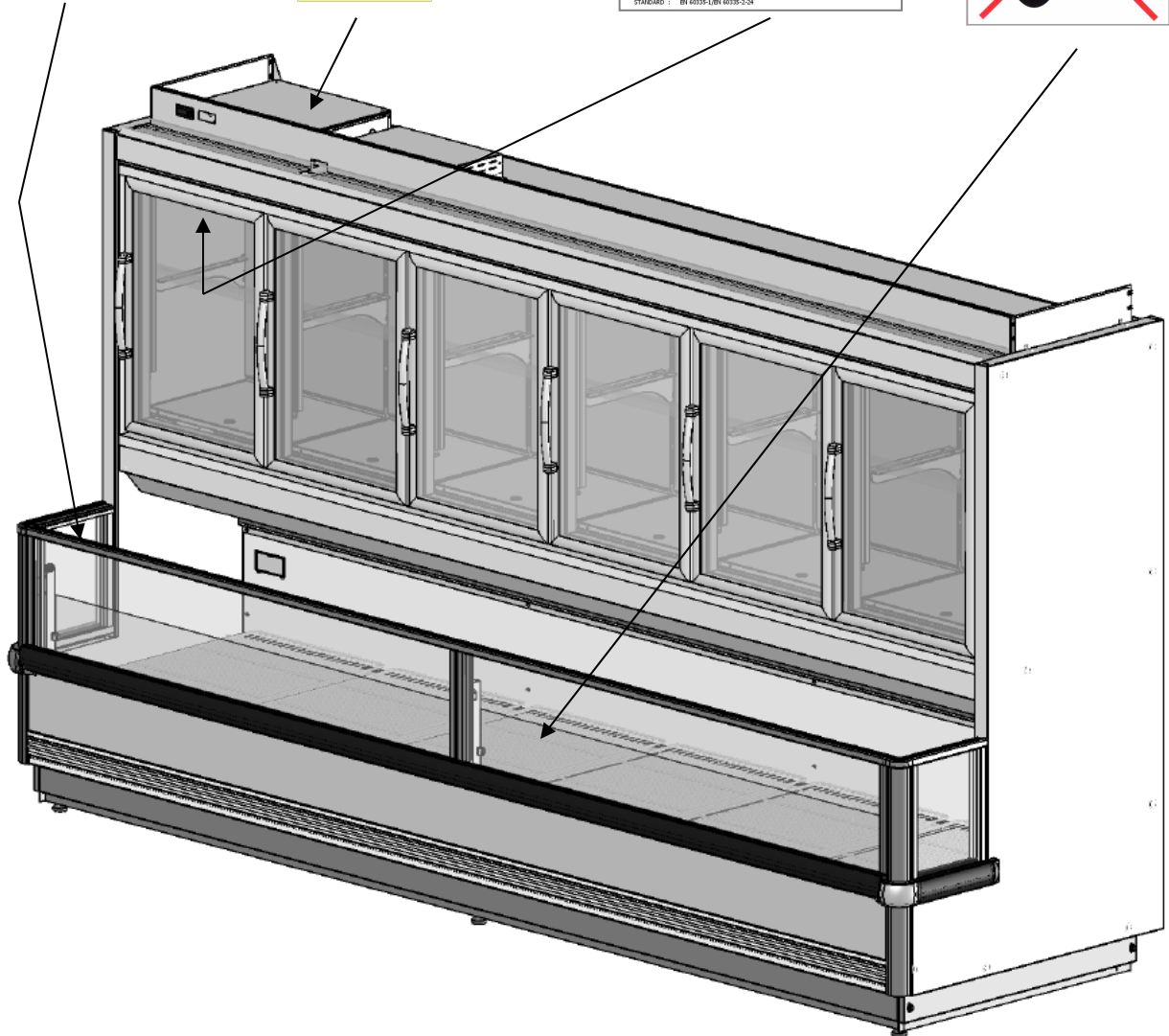

Pressure Sticker



**WARNING!**  
This Plank is under nitrogen pressure of 3 bar

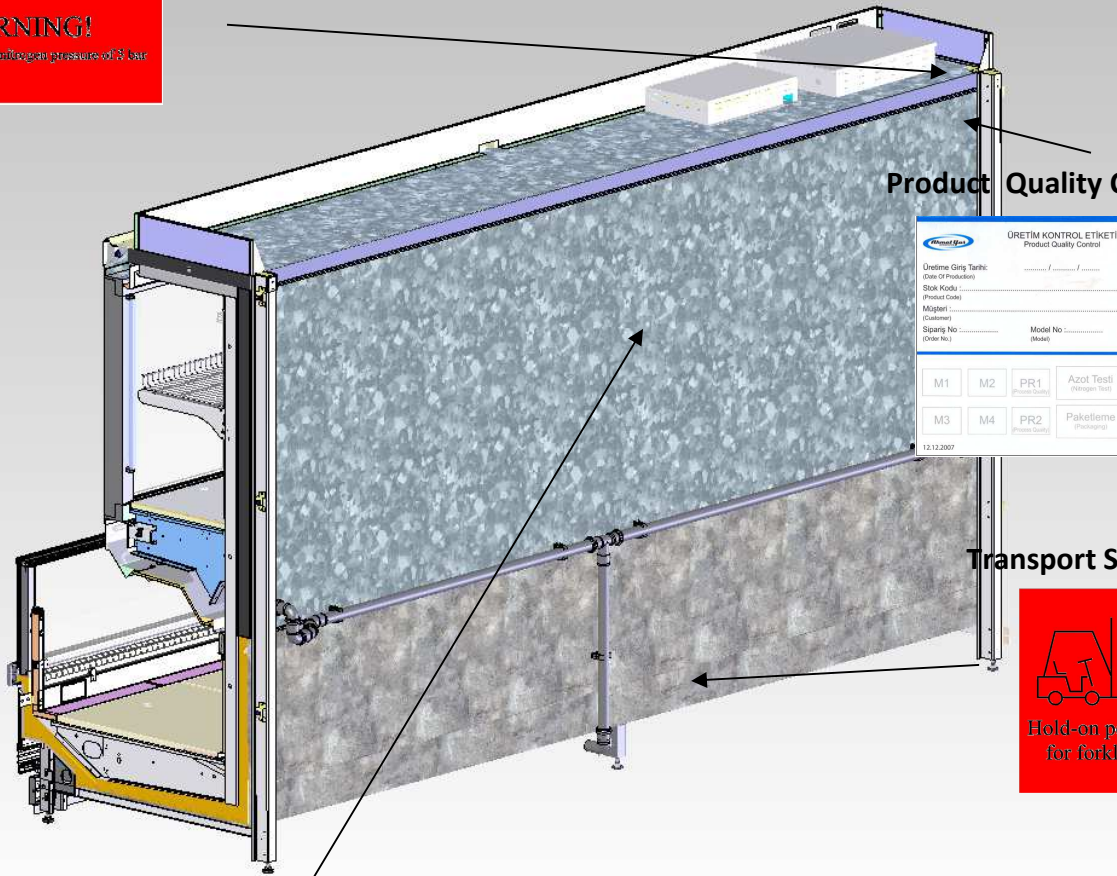

Product Quality Control

ÖRETİM KONTROL ETİKETİ Product Quality Control			
Üretim Giriş Tarihi: (Date Of Production) _____			
Şişe Kodu: (Product Code) _____			
Müşteri: (Customer) _____			
Sipariş No: (Order No.) _____		Model No: (Model) _____	
Modül: (Module) _____		Modül: (Mod. Size) _____	
M1	M2	PR1	Azot Testi (Nitrogen Test)
M3	M4	PR2	Paketleme (Packaging)
			Elektrik Testi (Electrical Test)
			Final Kalite (Final Quality)
Form No: _____			
Tarih: 12.12.2007			

Transport Sticker



Baltic SNG AHSPM Process Control

PROCESS CONTROL FORM		PASTE DESCRIPTION LABEL IN THIS AREA		
EPHEIUS CASE (EPHEIUS 1)		CHECK BY	CHECK BY	CHECK BY
OF HEADPHONE / ÜRÜN BAĞLAMA / ÜRÜN BAĞLAMA		DATE / TARİH	DATE / TARİH	DATE / TARİH
EXPLANATION:				
CONTROL OF THE PARTS				
MECHANICAL ASSEMBLY OF CASE				
1	BACK PANEL SUPPORT LEG	IS INFORMATION SHEET BEING INCORPORATED IN THE AMOUNT AND CORRECT ASSEMBLY?	01	
2	AIR REFLECTOR/SUPPORT SHEET FRONT AIR GRILL	ACCEPTABLE ANY INFORMATION IN THE PARTS?	01	
3	COILING BRIST / SUPPORT SHEET/BACK GRILL	ACCEPTABLE INFORMATION CORRECT COLOUR?	01	
4	UPPER/LOWER DECOR AND UPPER DECOR	ACCEPTABLE INFORMATION CORRECT COLOUR?	01	
5	BUMPER PROFILE	ACCEPTABLE INFORMATION CORRECT COLOUR?	01	
6	NIGHT BLIND	ACCEPTABLE CORRECT ASSEMBLY?	01	
7	BASE TRAYS	ACCEPTABLE INFORMATION CORRECT COLOUR/ISOLATION BAND?	01	
8	DECOR TOP PANEL (MAX TERM)	ACCEPTABLE INFORMATION CORRECT COLOUR?	01	
9	KAFI KÖBÜLÜŞE ÇÖZÜLÜŞÜ İÇİN İZOLASYON KARTI (MAX TERM)	ACCEPTABLE INFORMATION CORRECT COLOUR?	01	
10	INSULATED PLASTIC	ACCEPTABLE CORRECT COLOUR?	01	
11	ALL PAINTED PARTS	COMPATIBILITY CORRECT COLOUR?	01	
ELECTRICAL ASSEMBLY CONTROL				
12	PLATE OF PROBER ISOLATION OF PROBER (CABLE TIE)	ACCEPTABLE INFORMATION CORRECT COLOUR?	01	
13	FAN / COMMUNICATION CARD	ACCEPTABLE CORRECT?	01	
14	CONTROLLER DETAIL	CORRECT?	01	
15	ELECTRICAL TEST FORM	AVAILABLE?	01	
COOLING EQUIPMENTS AND ASSEMBLY CONTROL				
16	EXAM FINAL AND CHECK OF PIPE CONNECTIONS FOR WELDING	ACCEPTABLE?	01	
17	COOLING SYSTEM SERIAL NUMBER (REFRIGERANT, DRAHER ETC.)	CORRECT?	01	
18	DRAHER POSITION	CORRECT?	01	
ACCORDING TO THE DATA ABOVE THE ONLY CONTROL TO BE PERFORMED IS TO BE ALL OF THE INFORMATION CONTAINED IN THIS LABEL IS CORRECT AND TO BE ALL OF THE INFORMATION CONTAINED IN THIS LABEL IS CORRECT AND TO BE ALL OF THE INFORMATION CONTAINED IN THIS LABEL IS CORRECT				
NAME:		DATE / TARİH:		

Electrical Test Form

**Elektrik Test Formu**  
ELECTRICAL TEST FORM

**DİKKAT - TEST YAPARKEN KORUMA ELDİVENİNİ MUTLAKA TAKINIZ / ATTENTION - USE PROTECTIVE GLOVES WHILE PERFORMING TEST**

TARİH / DATE: \_\_\_\_\_  
SİPARİŞ NO / ORDER NO: \_\_\_\_\_  
SERİ NO / SERIAL NO: \_\_\_\_\_  
MÜŞERİ ADI / CUSTOMER NAME: \_\_\_\_\_  
MODEL: \_\_\_\_\_

*Test yapmadan önce cihaz kullanım talimatlarını okuyunuz!  
Please read manual before performing test!*

**FONKSİYON TESTİ (FUNCTION TEST)**

TEST NO: F1 - Kontrol / Control

AKN	ELSVİTEV	İletim	Watt

F3 - Fan / Fan  
F5 - Kabin Isıtıcıları / Rail heaters  
F7 - Aydınlatma / Lighting  
F9 - Defrost rezistansları / Defrost heaters  
F10 - Defrost rezistansları / Defrost heaters

**TOPRAKLAŞMA DİRENÇ TESTİ (CONTINUITY - 12V / 100V)**

TEST NO: **TOPRAK - PANO YERİNE ARASI ÖLÇÜM YAPINIZ / MEASURE PANEL TO GROUND**

Maksimum direnç / Maximum resistance (0 - 100ohm)  
Test akımı / Test current (0 - 25 A)  
Test süresi / Test time: 15 sn

**İZOLASYON TESTİ (INSULATION RESISTANCE - RESO 500V)**

TEST NO: **FAZ - TOPRAK VE NÖTR - TOPRAK ARASI ÖLÇÜM YAPINIZ / MEASURE PHASE TO GROUND AND NEUTRAL TO GROUND**

L1 - PE	L2 - PE	L3 - PE	N - PE	OK

Maksimum direnç / Maximum resistance (2M)  
Test voltajı / Test voltage (500 VDC)  
Test süresi / Test time: 15 sn

**YÜKSEK GERİLİM TESTİ (WITHSTANDING 1000V)**

TEST NO: **FAZ - TOPRAK VE NÖTR - TOPRAK ARASI ÖLÇÜM YAPINIZ / MEASURE PHASE TO GROUND AND NEUTRAL TO GROUND**

L1 - PE	L2 - PE	L3 - PE	N - PE	OK

Maksimum akım / Maximum current (0 - 10 mA)  
Test voltajı / Test voltage (1000 V)  
Test süresi / Test time: 30 sn

AD SOYAD / NAME SURNAME: \_\_\_\_\_ İMZA / SIGN: \_\_\_\_\_

KONTROL YAPILDI / CONTROLLED: \_\_\_\_\_  
SÖN KONTROL / FINAL CONTROL: \_\_\_\_\_  
Yayın Tarihi: 04.11.2007

Baltic SNG AHSPM Cabinet Function

**EPHEIUS CABINETS FUNCTION TESTS**

DATE: \_\_\_\_\_  
ORDER NO: \_\_\_\_\_  
SERIAL NUMBER: \_\_\_\_\_  
CUSTOMER: \_\_\_\_\_

FAN SPEED: \_\_\_\_\_  
FAN SPEED: \_\_\_\_\_  
FAN SPEED: \_\_\_\_\_

Applied Voltage	Measured Voltage	Test Result	Control
VOLTAGE	CURRENT	CURRENT	
Exp. Fan STANDARD			
Exp. Fan ENERGY SAVING			

DESCRIPTION: \_\_\_\_\_

CONTROLLED BY: \_\_\_\_\_ İMZA / SIGN: \_\_\_\_\_

## High Voltage Sticker

High voltage sticker is located on the electricity box.

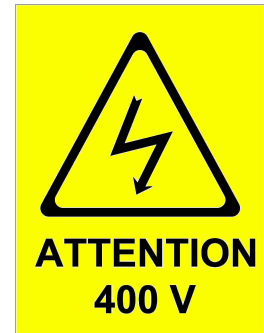

## Loading Sticker

There are palettes located on the refrigerator for transportation. Transportations with forklifts or transpalettes are materialized by the assistance of these palettes. There is a sticker behind the refrigerator about the transportation palettes

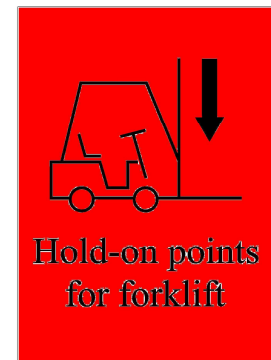

## Pressure Sticker

Pressure sticker is located at the exit points of the copper pipes. It is used for determining the quantity of nitrogen.



## Fragile Sticker

There are on the risk of fracture surfaces. Carefully moving is important and do not hit to hard materials. There are fragile stickers on the side walls.



## Foot Print Sticker

This sticker located on the base trays



Product Definition Sticker Product definition sticker is located inside the refrigerator on the ceiling and includes all technical properties.

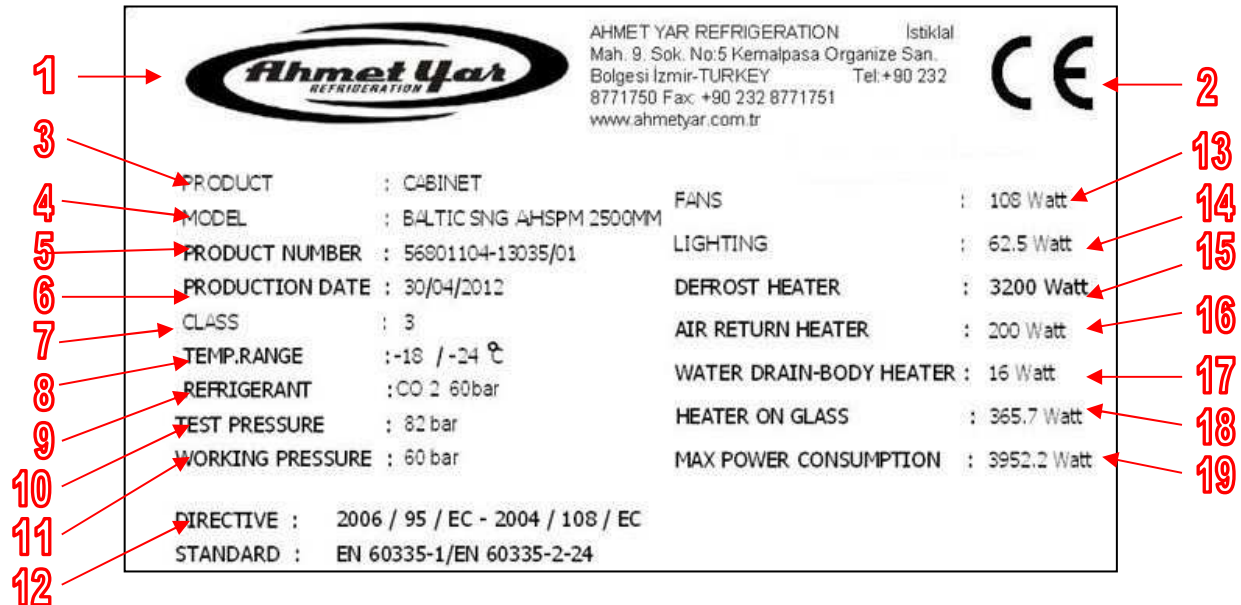

1. Logo and address info of the producer company
2. Product certificates and quality certificates of the producer
3. Model of the product
4. Article no
5. Serial number of the product
6. Production date of the product
7. Air conditioner class of the product
8. Temperature range of the cabinet
9. Type of refrigerant
10. Test pressure
11. Working pressure
12. Approved certificates of the product and the standards&directives
13. Power of fans info
14. Power of lights
15. Power of defrost heaters
16. Power of air return heaters
17. Power of drain heaters
18. Power of glass heaters
19. Max power consumption

## 6. Assembling and Environmental Situations

Respect the instructions below prior to assembling.

- Do not leave or assemble the refrigerator at the positions below ;
- Not close to any explosive gasses
- Not close to heaters
- Avoid draught area

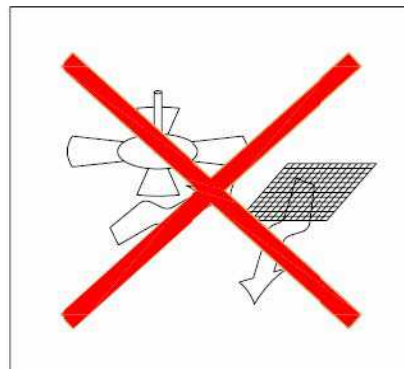
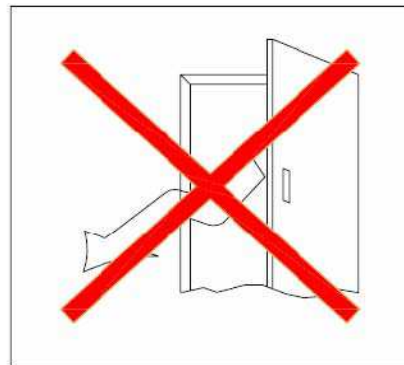
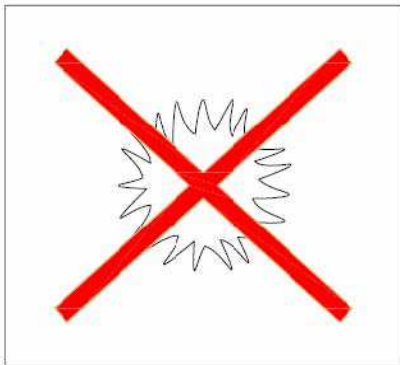

## 7. Loading Goods

Cabinet loading important rules that should be followed.

- Locate the goods to the shelves tidy.
- To install packages in the closet, set max and do not leave blank space.
- Between the top shelf loaded with goods leave the 30mm gap.
- ensure consumption of the substance and accordingly load.
- Except for the closet shelf and the base tray, do not install any goods

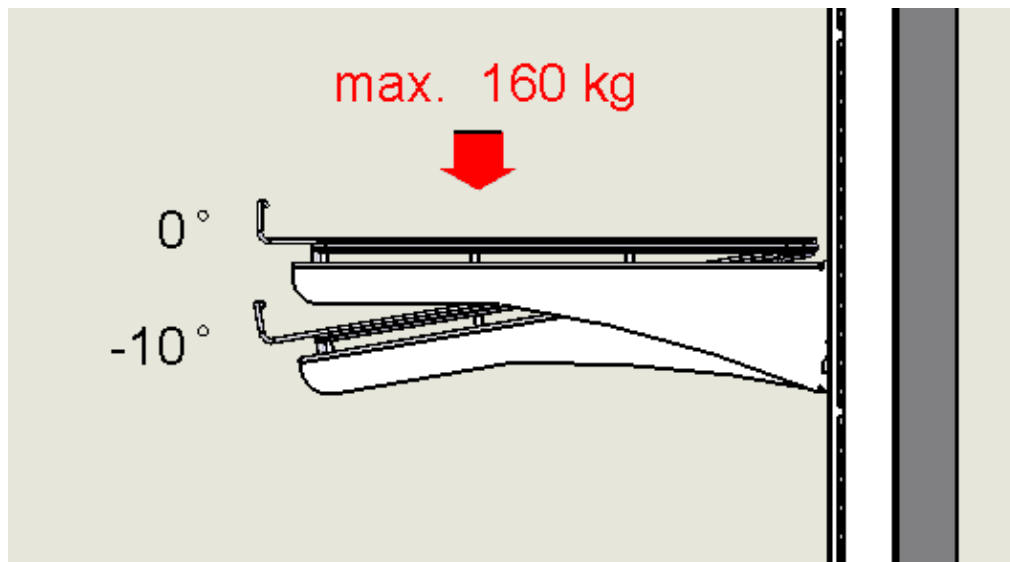

## 8. Multiplexing of cases

Follow the sequences below for connecting two or more refrigerators.

- Disassemble the endwalls ( if exist)
- Place the refrigerators closer to each other
- Disassemble the palette. Level the refrigerators by arranging the heights of cabinet legs. (Diagram 1-2) Check on the balance by using water ballance. Check the balance of the refrigerator by moving it.



Diagram-1

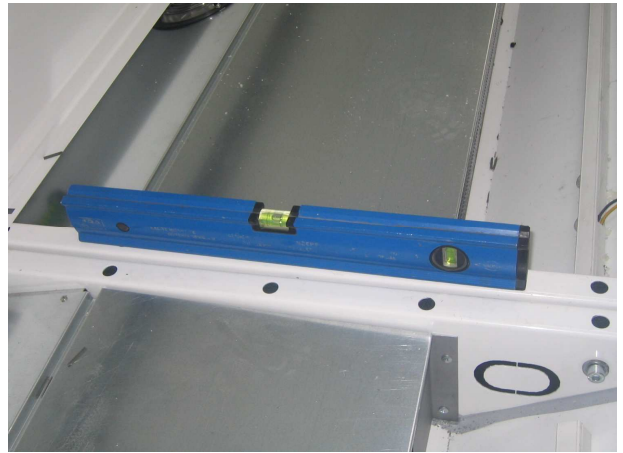

Diagram-2

### Side Pillar Connection

- Attach the connection equipments to the connection hole which is located near the refrigerator on the base tray pillars. Connection equipments and their locations are shown on the (Diagram 3).



Diagram-3

Baltic bottom bracket base assembling  
Section view

Baltic middle bracket base assembling  
Section view.

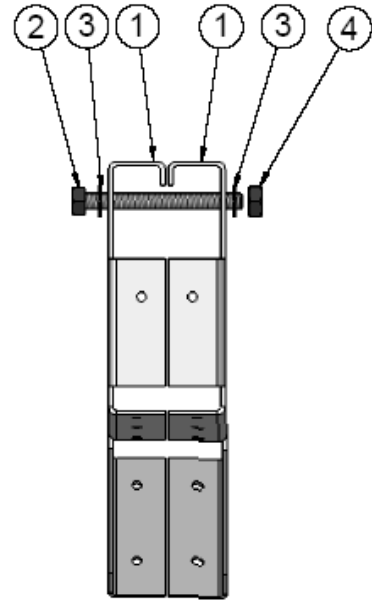
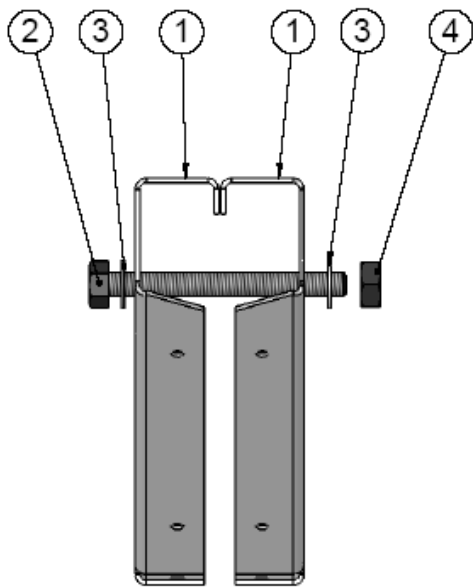

POS NO	MATERIAL NAME	UNIT
1	Side Pillar	On it
2	M8x100 Hexagonal screw	2
3	M8 Washer	4
4	M8 Nut	2



It needs to be connected from the side brackets with 3 screws as from the holes shown on the picture. (Diagram 3)



Diagram 3

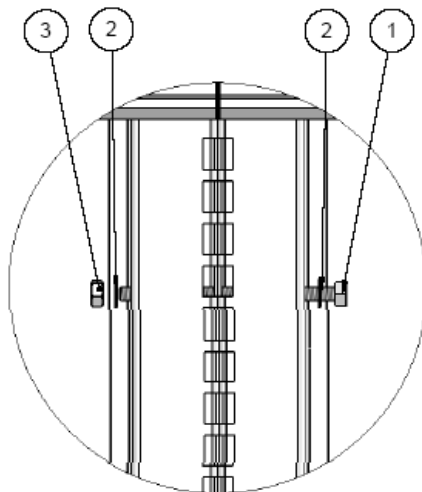

POS NO	MATERIAL NAME	UNIT
1	M8x150 6K covered screw	3
2	Washer	6
3	M8 Nut	3

**UPPER PANEL CONNECTIONS**

- There are two units of refrigerator connection sheets on the roof of the refrigerators and one connection sheet is located on the front lower body of the refrigerator. (Diagram 4-5)

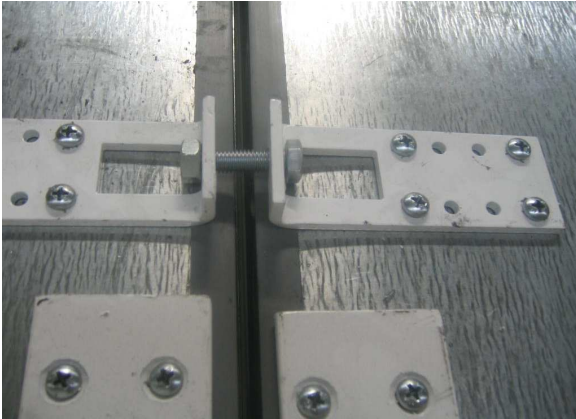
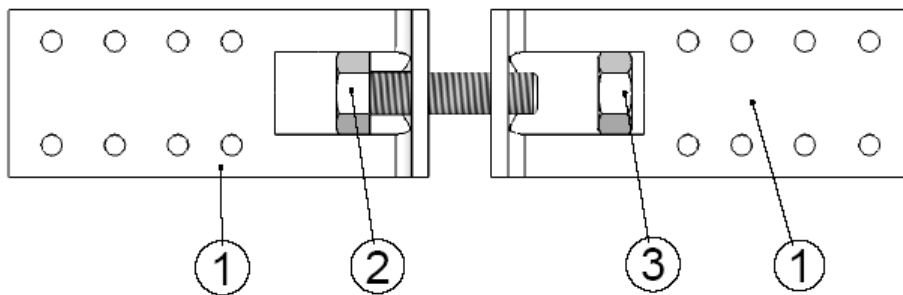

Diagram 4



Diagram 5



POS NO	MATERIAL NAME	UNIT
1	Multiplexing Kit	4
2	M8x40 Hexagonal Bolt	2
3	M8 Nut	2

## 9. Installation of Endwalls

For being able to connecting endwalls, first of all stick the isolation tape to the panel plastic and to the body polyurethane supporter. (The surfaces that isolation tape must be sticked are shown in Diagram 6)

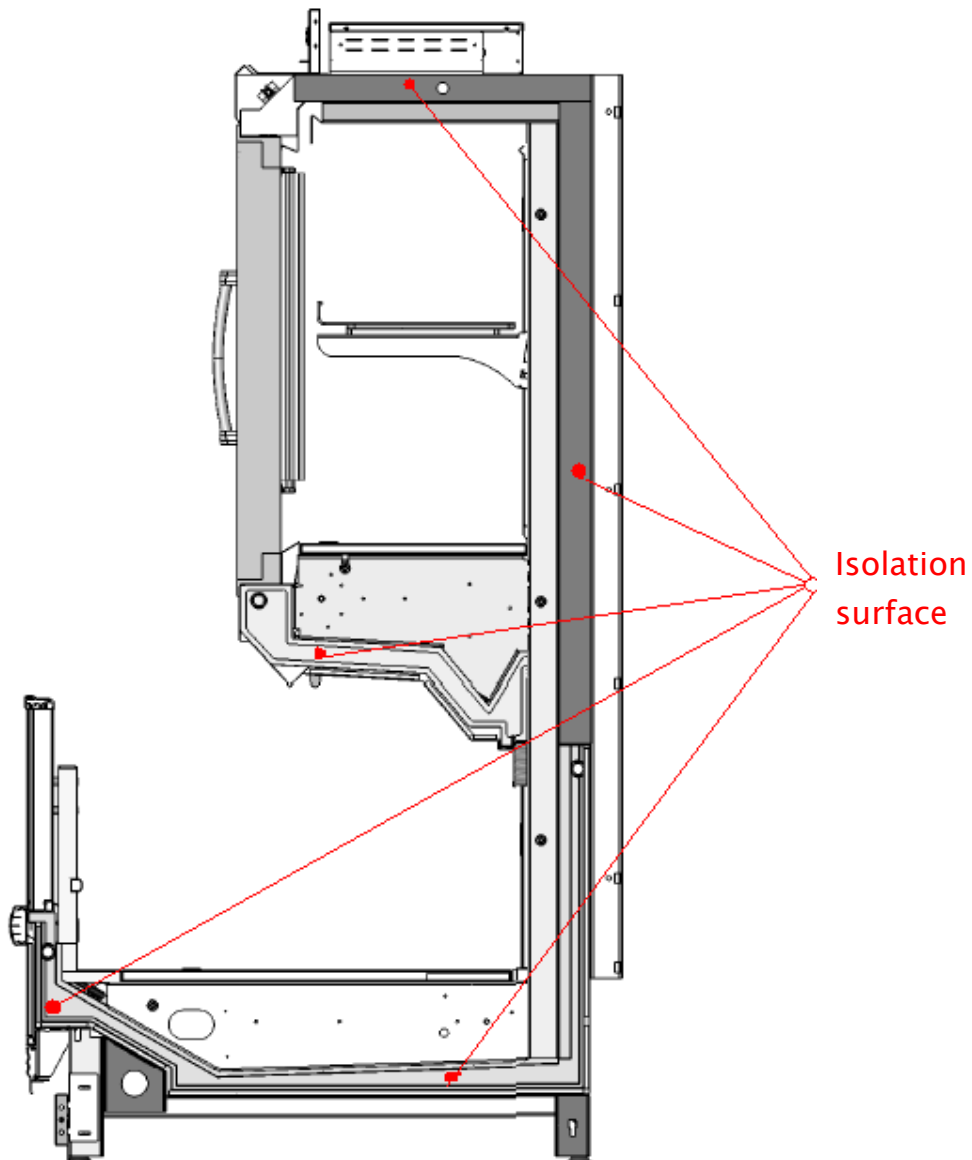
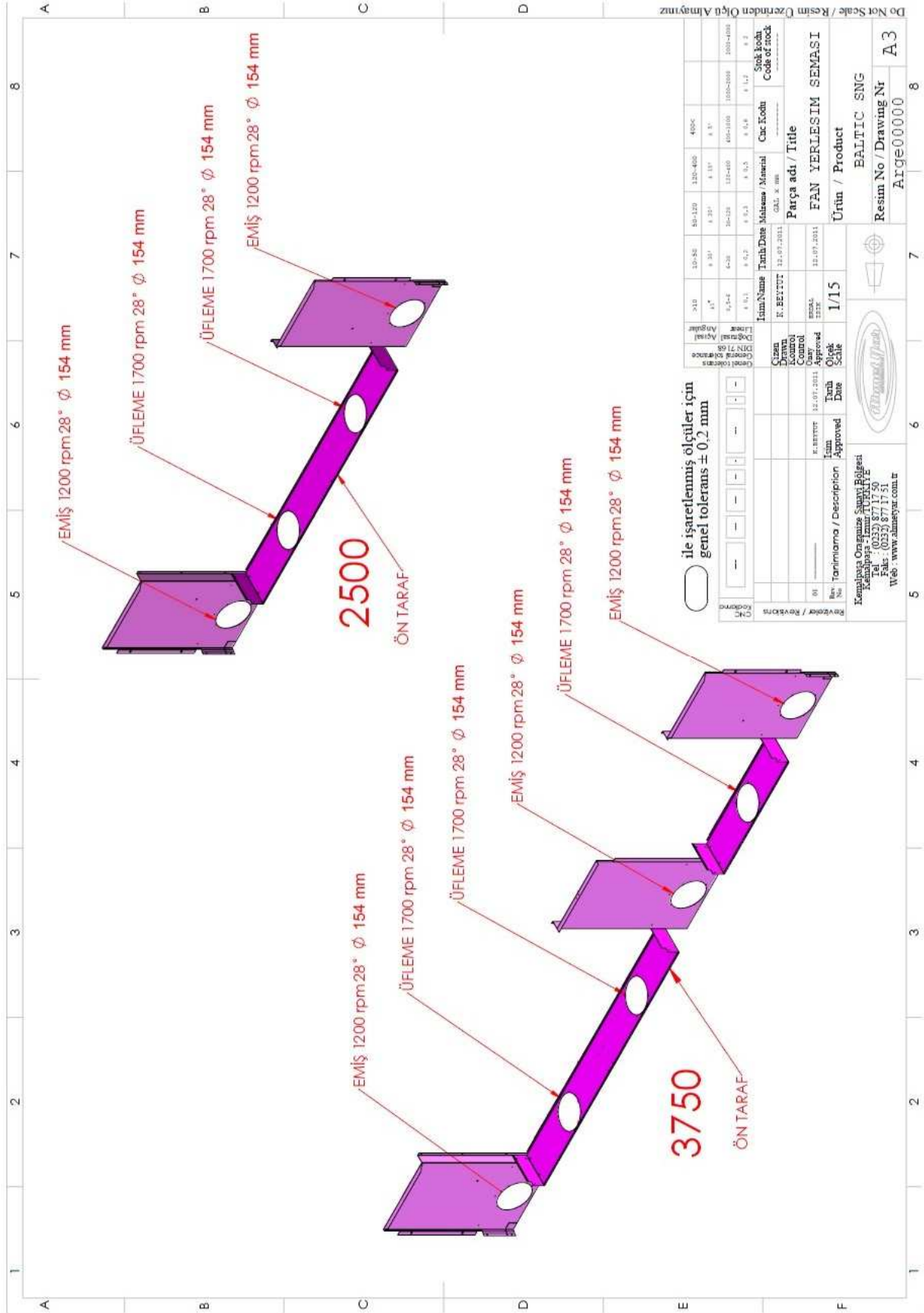

Diagram 6



# 10. Fan Connection



# 11. Prob Position

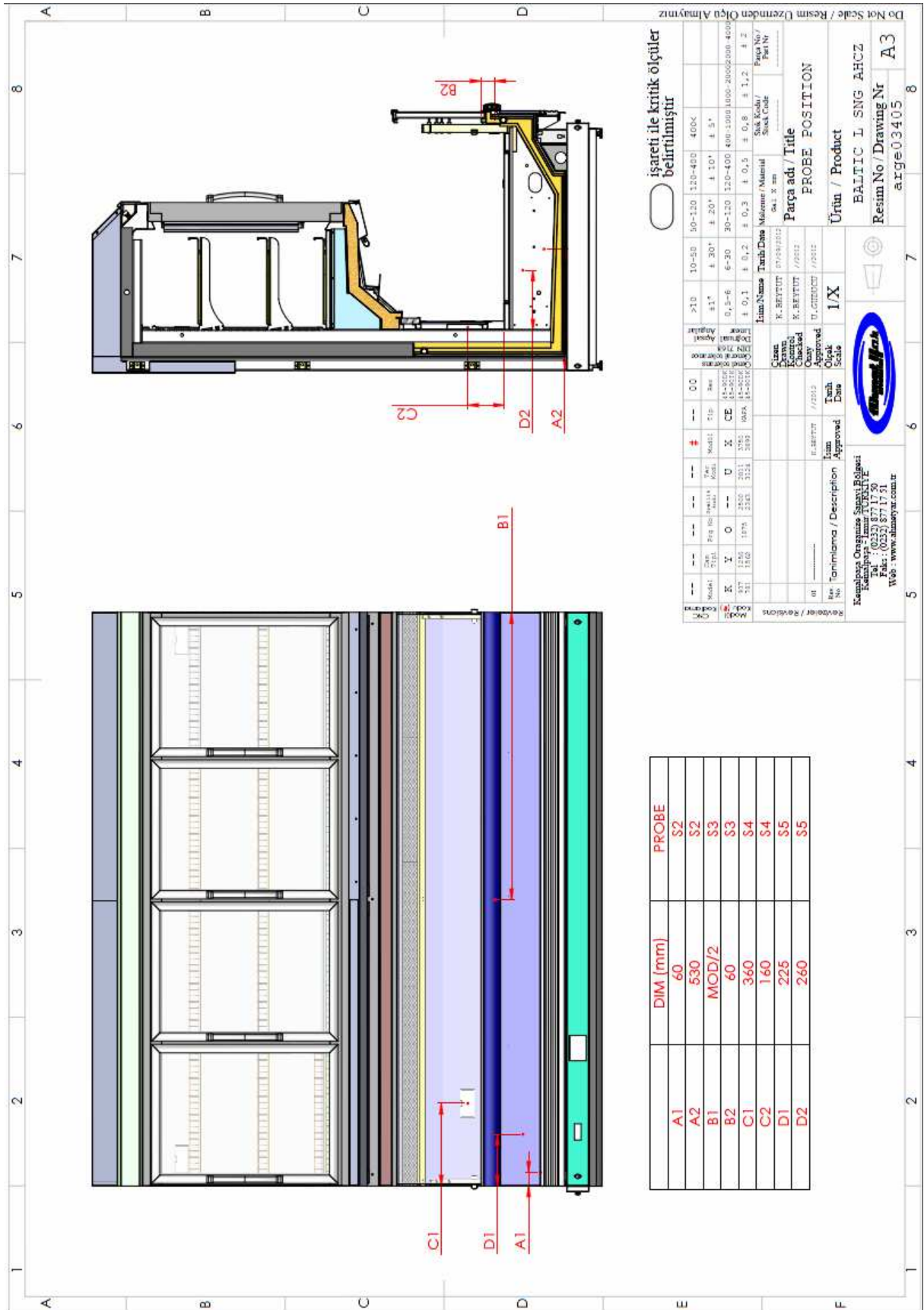

işareti ile kritik ölçüler belirtilmiştir

Do Not Scale / Resim Üzerinden Ölçü Almayınız	10-50	90-120	120-400	400K
>10	± 30"	± 20"	± 10"	± 5"
0,5-5	± 0,3	± 0,2	± 0,1	± 0,05
0,1-0,5	± 0,1	± 0,05	± 0,02	± 0,01
0,01-0,1	± 0,05	± 0,02	± 0,01	± 0,005
0,001-0,01	± 0,02	± 0,01	± 0,005	± 0,002
0,0001-0,001	± 0,01	± 0,005	± 0,002	± 0,001
0,00001-0,0001	± 0,005	± 0,002	± 0,001	± 0,0005
0,000001-0,00001	± 0,002	± 0,001	± 0,0005	± 0,0002
0,0000001-0,0000001	± 0,001	± 0,0005	± 0,0002	± 0,0001
0,00000001-0,00000001	± 0,0005	± 0,0002	± 0,0001	± 0,00005
0,000000001-0,000000001	± 0,0002	± 0,0001	± 0,00005	± 0,00002

Çizim / Drawing	R. BEYUT	17/03/2012
Kontrol / Checked	K. BEYUT	17/03/2012
Onay / Approved	U. GÖRÜKÇİ	17/03/2012
Ölçek / Scale	1/X	
Ürün / Product	BAL TIC L SNG AHCZ	
Resim No / Drawing Nr	arg03405	

Revizyon / Revisions

No	Tanımlama / Description	İlan / Approved	Tarih / Date
1			

Komşuluşa Ortaya Sırasıyla Bülencei Kömürhanesi - İsmail TÜRKALP  
 Tel. : (0332) 8711750  
 Faks : (0332) 8711731  
 Web : www.ahmetuyar.com.tr

---

## 12. Electricity Connection

Details below must be examined while making the electricity connections.

Attention!! Examine the definition stickers, informations and electricity diagrams on the product guide before making the electric connections.

- Protective automatic key and main power switch must be used against electric current on the refrigerator.
- Users must know where the key is kept in case of an emergency.
- Electric systems must be grounded.
- Maximum voltage difference must be guaranteed at  $\%+-6$ .
- The thickness of the cable on the power line must be sufficient but at least 2,5 mm<sup>2</sup>.
- The cable of power line must not exceed 5m, depends on the conditions if cable length increases the cable cross-section must be increased too.
- For making the refrigerator works regularly, be sure you obtained the heat and the damp values which are regarded at EN-23953-2 and be sure the climate class is 3.
- The personnel who will interfere to the refrigerator must be authorized.
- Always respect applicable local/national laws, legislative and norms.

## 13. Care&Cleaning

Long life and satisfactory performance of any equipment is dependent upon the care it receives. To ensure long life, proper sanitation and minimum maintenance costs, these display Cases should be thoroughly cleaned, all debris removed and the interiors washed down, weekly.



### Fan Plenum:

To facilitate cleaning, the fan plenum is hinged and also fastened with screws at each end. After cleaning be sure the plenum is properly lowered into position and that screws are reinstalled OR PRODUCT LOSS WILL RESULT due to improper refrigeration.

### Exterior Surfaces:

The exterior surfaces should be cleaned with a mild detergent and warm water to protect and maintain their attractive finish. NEVER USE ABRASIVE CLEANSERS OR SCOURING PADS.

### Interior Surfaces:

The interior surfaces may be cleaned with most domestic detergents, ammonia based cleaners and sanitizing solutions with no harm to the surface.

### DO NOT USE:

- Abrasive cleansers and scouring pads, as these will damage the finish.
- Solvent, oil or acidic based cleaners on any interior surfaces will cause damage.

! WARNING

**Do NOT use HOT water on COLD glass surfaces. This can cause the glass to shatter and could result in personal injury. Allow glass fronts, ends and service doors to warm before applying hot water.**



**Do:**

- Remove the product and all loose debris to avoid clogging the waste outlet.
- Store product in a refrigerated area such as a freezer. Remove only as much product as can be taken to the freezer in a timely manner.
- First turn off refrigeration, then disconnect electrical power.
- Thoroughly clean all surfaces with soap and hot water. Do not use steam or high water pressure hoses to wash the interior.
- These will destroy the display cases sealing causing leaks and poor performance.
- Remove screws and lift fan plenum for cleaning. Be sure to reposition the fan plenum after cleaning display case.
- Take care to minimize direct contact between fan motors and cleaning or rinse water.
- Rinse with hot water, but do not flood. Never introduce water faster than the waste outlet can remove it.
- Allow Display Cases to dry before resuming operation.
- After cleaning is completed, turn on power and refrigerant to the Display Case. Verify that Display Case is working properly

**Replacing fan motors and blades:**

See cross section for location of evaporator fans. Should it ever be necessary to service or replace the fan motors or blades be certain that the fan blades are re-installed correctly. THE BLADES MUST BE INSTALLED WITH RAISED EMBOSSED (PART NUMBER ON PLASTIC BLADES) POSITIONED AS INDICATED ON THE PARTS LIST. (Refer to the case data sheet for each model.)

For access to these fans:

- Turn off power.
- Remove bottom display pans.
- Disconnect fan from wiring harness.
- Remove fan blade.
- Lift fan plenum and remove screws holding bottom of motor to fan basket.
- Replace fan motor and blade.
- Lower fan plenum.
- Reconnect fan to wiring harness.

- Turn on power.
- Verify that motor is working and blade is turning in the correct direction.
- Close air gaps under fan plenum. Warmer air moving into refrigerated air reduces effective cooling. If the plenum does not rest against the case bottom without gaps, apply foam tape to the bottom of the fan plenum to reduce improper air movement. Use silicone sealant to close other gaps.
- Replace display pans. Bring Display Case to operating temperature before restocking.

**Defrost the display case every three months** to let the ice that may have formed between the fins melt. Frost may otherwise prevent correct operation. Proceed as follows.

- Disconnect the display case from the electrical power supply by the wall main cut-off switch.
- Empty the appliance, store the contents in cold rooms or refrigerators that are adequate for keeping the requisite preservation temperature.
- Wait until the cold room has reached ambient temperature.
- Clean the inside of the display case thoroughly with mild soap or detergent and lukewarm water. Wipe carefully with a soft cloth.
- After having carefully checked that the display case is completely dry inside, start the appliance again by the wall cut-out switch.
- Allow a couple of hours before loading the products back again.

## 14. Recycle Parts

All countries are disposing of waste according to EU laws and norms

Current Recycle Parts on the case;

- Painted Metals :Pillars ,shelves ,legs, back panel, base tray, ceiling
- Copper, Aluminium :Evaporator and electrical parts
- Stainless Steels :Bottom panels ,painted panels ,basic parts , base tray
- Polyurethane :Thermal injection
- Thermopane :Glass parts
- PVC :Handrails
- Polystyrene :Side endwalls
- Polycarbon :Led Lighting cover

# 15. Spare Parts

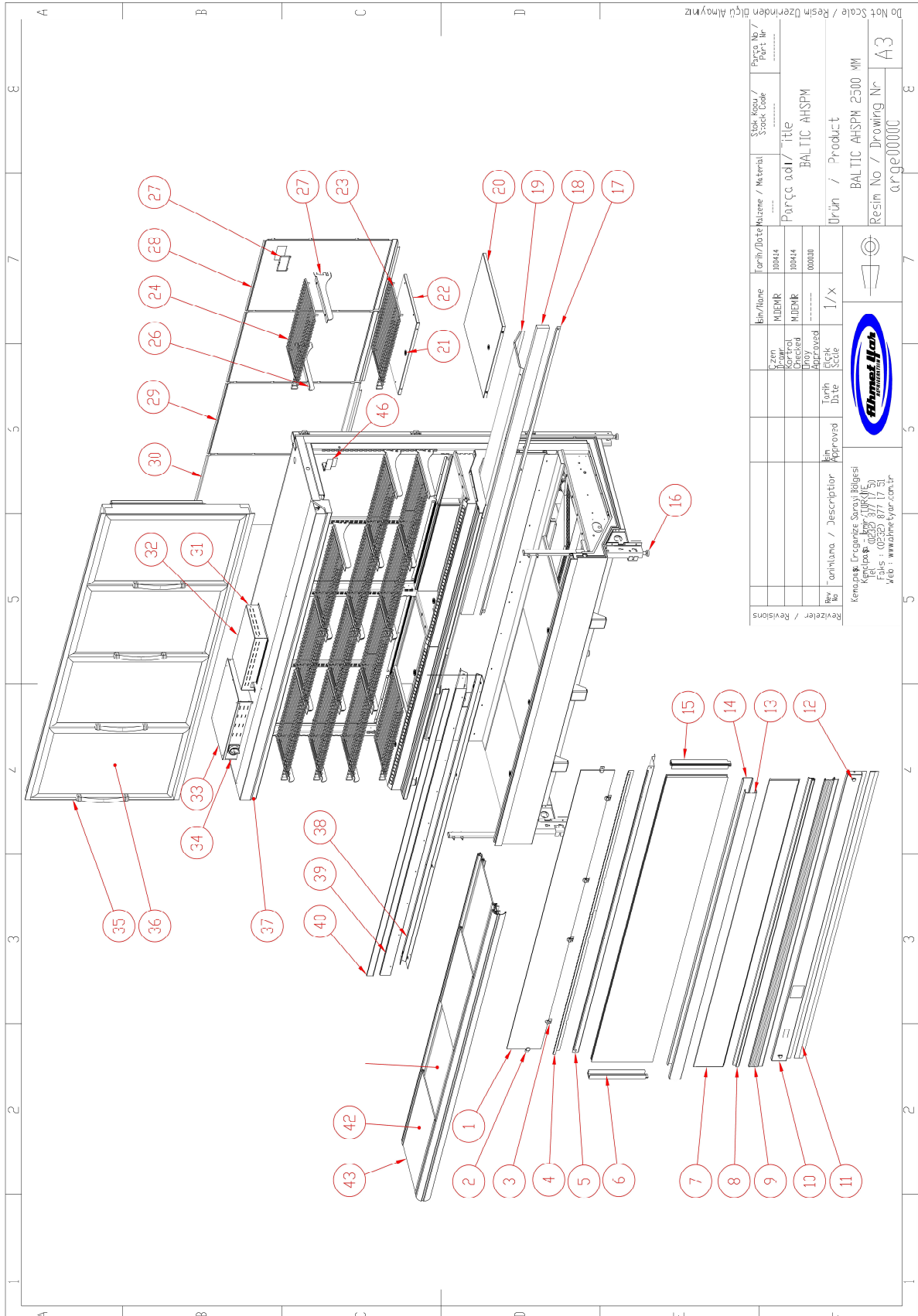

Rev. No / Yazdırma / Control Approved	Rev. No / Yazdırma / Control Approved	Rev. No / Yazdırma / Control Approved	Rev. No / Yazdırma / Control Approved	Rev. No / Yazdırma / Control Approved	Rev. No / Yazdırma / Control Approved	Rev. No / Yazdırma / Control Approved	Rev. No / Yazdırma / Control Approved	Rev. No / Yazdırma / Control Approved	Rev. No / Yazdırma / Control Approved
Revizyonlar / Revisions									
Kullanım / Description									
Kampanya / Campaign									
Kullanım / Description									
Kampanya / Campaign									
Kullanım / Description									
Kampanya / Campaign									
Kullanım / Description									
Kampanya / Campaign									

Revizyon / Date	Revizyon / Date	Revizyon / Date	Revizyon / Date	Revizyon / Date	Revizyon / Date	Revizyon / Date	Revizyon / Date	Revizyon / Date	Revizyon / Date
1 / X	1 / X	1 / X	1 / X	1 / X	1 / X	1 / X	1 / X	1 / X	1 / X
Kampanya / Campaign									
Kullanım / Description									
Kampanya / Campaign									
Kullanım / Description									
Kampanya / Campaign									
Kullanım / Description									
Kampanya / Campaign									

Revizyon / Date	Revizyon / Date	Revizyon / Date	Revizyon / Date	Revizyon / Date	Revizyon / Date	Revizyon / Date	Revizyon / Date	Revizyon / Date	Revizyon / Date
1 / X	1 / X	1 / X	1 / X	1 / X	1 / X	1 / X	1 / X	1 / X	1 / X
Kampanya / Campaign									
Kullanım / Description									
Kampanya / Campaign									
Kullanım / Description									
Kampanya / Campaign									
Kullanım / Description									
Kampanya / Campaign									

Revizyon / Date	Revizyon / Date	Revizyon / Date	Revizyon / Date	Revizyon / Date	Revizyon / Date	Revizyon / Date	Revizyon / Date	Revizyon / Date	Revizyon / Date
1 / X	1 / X	1 / X	1 / X	1 / X	1 / X	1 / X	1 / X	1 / X	1 / X
Kampanya / Campaign									
Kullanım / Description									
Kampanya / Campaign									
Kullanım / Description									
Kampanya / Campaign									
Kullanım / Description									
Kampanya / Campaign									

Revizyon / Date	Revizyon / Date	Revizyon / Date	Revizyon / Date	Revizyon / Date	Revizyon / Date	Revizyon / Date	Revizyon / Date	Revizyon / Date	Revizyon / Date
1 / X	1 / X	1 / X	1 / X	1 / X	1 / X	1 / X	1 / X	1 / X	1 / X
Kampanya / Campaign									
Kullanım / Description									
Kampanya / Campaign									
Kullanım / Description									
Kampanya / Campaign									
Kullanım / Description									
Kampanya / Campaign									

Revizyon / Date	Revizyon / Date	Revizyon / Date	Revizyon / Date	Revizyon / Date	Revizyon / Date	Revizyon / Date	Revizyon / Date	Revizyon / Date	Revizyon / Date
1 / X	1 / X	1 / X	1 / X	1 / X	1 / X	1 / X	1 / X	1 / X	1 / X
Kampanya / Campaign									
Kullanım / Description									
Kampanya / Campaign									
Kullanım / Description									
Kampanya / Campaign									
Kullanım / Description									
Kampanya / Campaign									

Do Not Scale / Resim Üzerinden Ölçülmemiştir

**BALTIC SNG AHSPM SPARE PARTS LIST**

POS	PART NO	DESCRIPTION	PCS		UNIT
			2500	3750	
1	23619960	DEEPFREEZE INTERNAL GLASS SECURIT (2430x220x6 mm)	1		pcs.
	23619959	DEEPFREEZE INTERNAL GLASS SECURIT (1825x220x6 mm)		2	pcs.
2	23700719	DEEP FREEZE PROFIL FRONT GLASS CONNECTION PLS ( HD-304 )	2	3	pcs.
3	23700711	DEEP FREEZE FRONT GLASS FRONT SUCTION CONNECTION PLS WHITE HD-302)	4	6	pcs.
4	46802079	BALTIC SNG LOWER FRONT EMS SHEET 1250 MM PAINTED	2	3	pcs.
5	46804037	BALTIC SNG HFG FRONT BASE HOLDER SHEET 2500 MM PAINTED	1		pcs.
	46806037	BALTIC SNG HFG FRONT BASE HOLDER SHEET 3750 MM PAINTED		1	pcs.
6	10411002	SIDE PROFILE FOR FRONT GLASS	0,5	0,5	pcs.
7	46804036	BALTIC SNG HFG LOWER DECOR SHEET 2500 MM PAINTED	1		pcs.
	46806036	BALTIC SNG HFG LOWER DECOR SHEET 3750 MM PAINTED		1	pcs.
8	10310216	KN:6228 HDF LOWER DECOR UPPER SHEET - 2500 mm - RAL 9006 PAINTED	1		pcs.
	10310217	KN:6228 HDF LOWER DECOR UPPER SHEET - 3800 mm - RAL 9006 PAINTED		1	pcs.
9	10310214	KN: 6227 HDF LOWER DECOR LOWER SHEET - 2550 mm - RAL 9006 PAINTED	1		pcs.
	10310215	KN: 6227 HDF LOWER DECOR ALTSHEET - 3800 mm - RAL 9006 PAINTED		1	pcs.
10	46804053	BALTIC SNG KICKPLATE 2500 MM PAINTED	1		pcs.
	46806053	BALTIC SNG KICKPLATE 3750 MM PAINTED		1	pcs.
11	10410203	KICKPLATE RUBBER NEW TYPE 2550 mm. - (R07 BLACK) (60008)	1		pcs.
	10410202	KICKPLATE RUBBER NEW TYPE 3800 mm. - (R07 BLACK) (60008)		1	pcs.
12	24019941	KNOW SCREW BASE M6*21 GREY (LONG)	2	3	pcs.
13	10411009	DEEP FREEZE BUMPER PROFILE 2550 mm. - R 515 LIGHT GREY (HD-106 76006)	1		pcs.
	10411010	DEEP FREEZE BUMPER PROFILE 3800 mm. - R 515 LIGHT GREY (HD-106 76006)		1	pcs.
14	10320033	KN:5958 HDF BUMPER HOLDER ALIMINUM - WITH ELOKSAL (SM11) 2600 mm.	1		pcs.
	10320032	KN:5958 HDF BUMPER HOLDER ALIMINUM - WITH ELOKSAL (SM11) 3800 mm.		1	pcs.
15	10411002	SIDE PROFILE FOR FRONT GLASS	0,5	0,5	pcs.
16	24019908	FOOT BOLT M16*90 (RUBBER)	4	6	pcs.
17	46804054	BALTIC SNG HONEY COMB HOLDER SHEET 2500 MM PAINTED	1		pcs.
	46806054	BALTIC SNG HONEY COMB HOLDER SHEET 3750 MM PAINTED		1	pcs.
18	40017002	HONEY COMB 1250*82 MM	2	3	pcs.
19	46804022	AHSPM MIDDLE BODY LOWER CLOSING COVER SHEET_1 2500 MM PAINTED	1		pcs.
	46806022	AHSPM MIDDLE BODY LOWER CLOSING COVER SHEET_1 3750 MM PAINTED		1	pcs.
20	46802168	BALTIC SNG LOWER BASE PAINTED ASSEMBLED 625*643 MM	4	6	pcs.
21	23700223	BASE RUBBER PLUG Q35 WHITE TESCO	4	6	pcs.
22	46802169	BALTIC SNG UPPER BASE PAINTED ASSEMBLED 625*427.5 MM	4	6	pcs.
23	23650128	BALTIC WIRE GRID (AHOLD CEK CUMH.I) SPECIAL AHOLD COLOR	4	6	pcs.
24	23650127	BALTIC WIRE SHELF (AHOLD CEK CUMH.I) SPECIAL AHOLD COLOR	12	18	pcs.
25	40002064	PAMUKKALE SHELF ARM RIGHT PAINTED	12	18	pcs.
26	40002065	PAMUKKALE SHELF ARM LEFT PAINTED	12	18	pcs.

27	23700780	DEEP FREEZE PROBE COVER (100006) RAL 9006 GREY	3	3	pcs.
28	46802042	BALTIC SNG AHSPM BACK PANEL RIGHT 625 MM PAINTED	1	1	pcs.
29	46802041	BALTIC SNG AHSPM BACK PANEL MIDDLE 625 MM PAINTED	2	4	pcs.
30	46802043	BALTIC SNG AHSPM BACK PANEL LEFT 625 MM PAINTED	1	1	pcs.
31	32200252	BALLAST BOX SHEET	1	1	pcs.
32	32200253	BALLAST BOX COVER SHEET	1	1	pcs.
33	36800251	PILOT BOX COVER SHEET	1	1	pcs.
34	36800250	PILOT BOX SHEET	1	1	pcs.
35	23960129	LED FRAME 947x2497 mm M4 NEGATIVE NUALIGHT 5100 K - BENT CAM	1		pcs.
	23960130	LED FRAME 947x3747 mm M6 NEGATIVE NUALIGHT 5100 K - BENT CAM		1	pcs.
36	23990259	LID 607x895 mm. NEGATIVE WITH HANDLE (AHOLD CEK CUMH.) - BENT CAM	4	6	pcs.
37	46804109	BALTIC SNG AHSPM UPPER DECOR SHEET 2500 MM PAINTED	1		pcs.
	46806109	BALTIC SNG AHSPM UPPER DECOR SHEET 3750 MM PAINTED		1	pcs.
38	46804132	AHSPM SLIDING GLASS LOWER CONNECTION SHEET 2500 MM PAINTED	1		pcs.
	46806132	AHSPM SLIDING GLASS LOWER CONNECTION SHEET 3750 MM PAINTED		1	pcs.
39	46804021	AHSPM MIDDLE BODY LOWER CLOSING COVER SHEET_2 2500 MM PAINTED	1		pcs.
	46806021	AHSPM MIDDLE BODY LOWER CLOSING COVER SHEET_2 3750 MM PAINTED		1	pcs.
40	10411322	SHELF PRICE STRIP (AHOLD CEK CUMH.)	2	3	pcs.
41	23610928	LOWER SLIDING GLASS AHSPM 2500-3750	2	3	pcs.
42	23610927	UPPER SLIDING GLASS AHSPM 2500-3750	2	3	pcs.
43	23611224	SLIDING GLASS SYSTEM 2500 MM	1		pcs.
	23611225	SLIDING GLASS SYSTEM 3750 MM		1	pcs.

Haz. : M. Demirgunes

Yayın Tarihi : 10.05.2014 - Rev.No : 00

# 16. Electrical Diagrams.

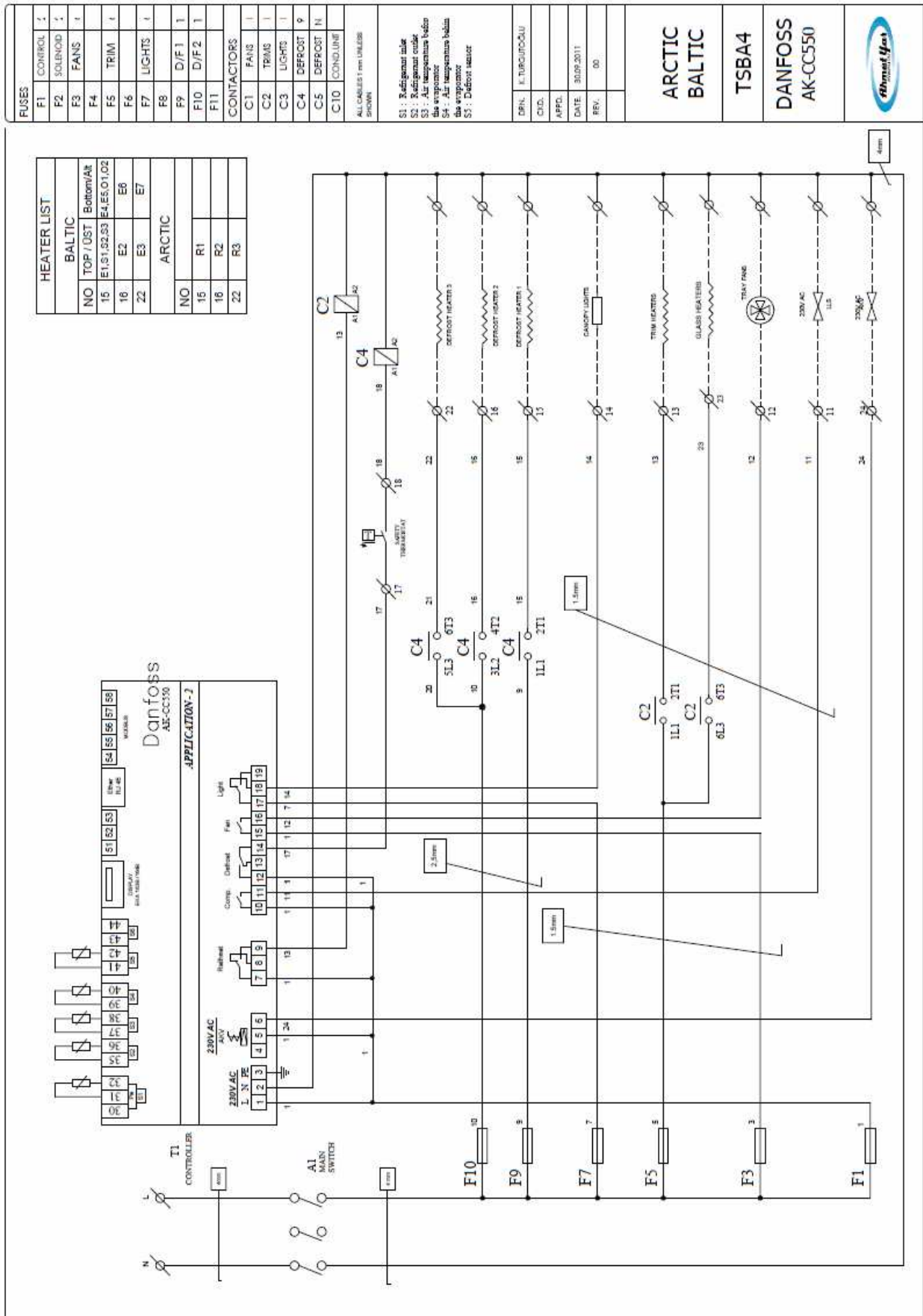

CAREL PARAMETERS		ISLAND FREEZER	WALL FREEZER	COMBI FREEZER	UPRIGHT FREEZER	COUNTER	MULTIDECK CABINET
<b>/Pro ( Prob parameters)</b>							
<b>/2</b>	Measurement stability		4	4	4	4	4
<b>/4</b>	Virtual Prob: Blowing and suction probes rates for regulation		100	100	100	50	50
	0= Blow probe						
	100= Suction probe						
<b>/5</b>	°C or °F selection		0	0	0	0	0
	0=°C, 1=°F						
<b>/6</b>	Decimal		1	1	1	1	1
	0=active,						
	1= inactive						
<b>rHS</b>	Virtual probe regulation rate to calculate glass temperature		20	20	20	20	20
	0= Blow probe						
	100= Suction probe						
<b>/t</b>	Are signals and alarms viewed in non-button terminal?		0	0	0	0	0
	0= inactive						
	1= active						
<b>/t1</b>	probe to be viewed in button terminal		12	12	12	12	12
	0 = Terminal inactive	8 =Serial probe 8					
	1 = Probe 1	9 =Serial probe 9					
	2 = Probe 2	10 =Serial probe 10					
	3 = Probe 3	11 =Serial probe 11					
	4 = Probe 4	12 = Control probe					
	5 = Probe 5	13 = Virtual probe					
	6 = Probe 6	14 = Set point					
	7 = Probe 7						
<b>/t2</b>	probe to be viewed in non-button terminal		12	12	12	12	12
	0 = Terminal inactive	8 =Serial probe 8					
	1 = Probe 1	9 =Serial probe 9					
	2 = Probe 2	10 =Serial probe 10					
	3 = Probe 3	11 =Serial probe 11					
	4 = Probe 4	12 = Control probe					
	5 = Probe 5	13 = Virtual probe					
	6 = Probe 6	14 = Set point					
	7 = Probe 7						

CAREL PARAMETERS			ISLAND FREEZER	WALL FREEZER	COMBI FREEZER	UPRIGHT FREEZER	COUNTER	MULTIDECK CABINET
/to	button/non-button terminal configuration		3	3	3	3	3	3
	<b>Button terminal</b>	<b>Non-button terminal</b>						
	0 Yes	yes						
	1 optional	yes						
	2 Yes	optional						
3 optional	optional							
/P1	S1 ,S2 , S3 (Group 1) probe type		0	0	0	0	0	0
	0 = NTC Standard Range -50T90°C							
	1 = PTC Standard Range -50T150°C							
	2 = PT1000 Standard Range -50T150°C							
	3 = NTCL243 Standard Range -50T90°C							
/P2	S4 ,S5 (Group2) probe type		0	0	0	0	0	0
	0 = NTC Standard Range -50T90°C							
	1 = PTC Standard Range -50T150°C							
	2 = PT1000 Standard Range -50T150°C							
	3 = NTCL243 Standard Range -50T90°C							
/P3	S6 (Group3) probe type		4	4	4	4	4	4
	0 = NTC Standard Range -50T90°C							
	1 = PTC Standard Range -50T150°C							
	2 = PT1000 Standard Range -50T150°C							
	3 = NTCL243 Standard Range -50T90°C							
4 = 0 to 5V ratiometric pressure transmitter								
/P4	S7, (Group4) probe type		0	0	0	0	0	0
	0 = NTC Standard Range -50T90°C							
	1 = PTC Standard Range -50T150°C							
	2 = PT1000 Standard Range -50T150°C							
	3 = NTCL243 Standard Range -50T90°C							
	4 = 0 to 5V ratiometric pressure transmitter							
	5 = 0 to 10 V input							
6 = 4 to 20 mA input								
/P5	S8 den S11 e (Group5) serial problar probe type		0	0	0	0	0	0





CAREL PARAMETERS		ISLAND FREEZER	WALL FREEZER	COMBI FREEZER	UPRIGHT FREEZER	COUNTER	MULTIDECK CABINET
<b>CtL ( Control)</b>							
<b>OFF</b>	ON/OFF control unit on-off		0	0	0	0	0
	0 = ON; 1 = OFF;						
<b>St</b>	Set point		-20	-20	-20	-20	2
<b>St2</b>	Double thermostate control suction set value		50	50	50	50	50
<b>rd</b>	St set value difference		2	2	2	2	2
<b>rd2</b>	Double thermostate control suction set value difference		0	0	0	0	0
	0.0 = Function inactive						
<b>r1</b>	Allowed minimum set value		-24	-24	-24	-24	-4
<b>r2</b>	Allowed maximum set value		-18	-18	-18	-18	4
<b>r3</b>	Defrost warning activation ending in time		0	0	0	0	0
	0 = inactive, 1 = active						
<b>r4</b>	Automatic night set point		0	0	0	0	0
<b>r5</b>	Will minimum and maximum temperatures be kept to which probe in the memory?		1	1	1	1	1
	0 = Monitoring inactive						
	1 = Control probe (Sreg)						
	2 = virtual probe (Sv)						
	3 = Blow probe (Sm)						
	4 = defrost probe (Sd)						
5 = Suction probe (Sr)							
6 = superheat temperature probe (tGS)							
7 = saturated evaporation temperature probe (tEu)							
8 = auxiliary defrost probe (Sd2)							
9 = auxiliary probe (Saux)							
10 = auxiliary probe 2 (Saux2)							
<b>rt</b>	Recorded min and max temperature monitoring time range		-	-	-	-	-
<b>rH</b>	Recorded max temperature		-	-	-	-	-
<b>rL</b>	Recorded min temperature		-	-	-	-	-
<b>r6</b>	Night Control probe		0	0	0	0	0
	0 = virtual probe Sv; 1 = Suction probe Sr						
<b>ro</b>	For Virtual Probe, probe error offset		0.0	0.0	0.0	0.0	0.0
<b>r7</b>	Master solenoid valve configuration		0	0	0	0	0
	0 = local valve ;1 = network valve (connected to the Master)						
<b>rSu</b>			0	0	0	0	0

CAREL PARAMETERS			ISLAND FREEZER	WALL FREEZER	COMBI FREEZER	UPRIGHT FREEZER	COUNTER	MULTIDECK CABINET
<b>CMP (compressor)</b>								
<b>c0</b>	Compressor and fan starting time delay		0	0	0	0	0	0
<b>c1</b>	Minimum time between successive start		0	0	0	0	0	0
<b>c2</b>	Compressor minimum OFF Time		0	0	0	0	0	0
<b>c3</b>	Compressor minimum ON Time		0	0	0	0	0	0
<b>c4</b>	Control probe error duty time. Compressor and solenoid outlet works for the time stated there		0	0	0	0	0	0
	holds for 15 minutes and works again.							
	0 = Compressor/valve always OFF; 100 = compressor/valve always ON							
<b>cc</b>	Continuous cycle time		1	1	1	1	1	1
<b>c6</b>	Post-continuous cycle alarm by-pass		60	60	60	60	60	60
<b>c7</b>	Maximum pump down time		0	0	0	0	0	0
<b>Def (defrost)</b>								
<b>d0</b>	Defrost type		4	0	0	0	0	0
	0 =temperature-based heater							
	1 = temperature-based hot gas							
	2 = temperature-based heater							
	3 = time-based hot gas							
4 =time and temperature-based heater defrost								
<b>d2</b>	Defrost-end synchronization by Master		1	1	1	1	1	1
	0 = unsynchronous; 1 = synchronous							
<b>d1</b>	Time between defrosts		8	8	6	6	6	6
<b>dt1</b>	Defrost-end temperature, Evaporator Sd1		10	10	12	12	10	10
<b>dt2</b>	Defrost-end temperature,AUX Evaporator Sd2		10	10	12	12	10	10
<b>dP1</b>	Maximum Defrost time		35	35	40	45	45	45
<b>dP2</b>	Maximum Defrost time, AUX 2. Evaporator		35	35	40	45	45	45
<b>d4</b>	Initially defrost		0	0	0	0	0	0
	0 = No initial defrost ; 1 = inital defrost							
	(Master = network defrost; Slave = local defrost)							
<b>d5</b>	Defrost time delay at the beginning if d4=1		0	0	0	0	0	0
	0 = delay inactive							
<b>d6</b>	Terminal indicator status during defrost		2	2	2	2	2	2
	0 = Real temperature value and "dEF" flashes							
	1 = pre-defrost last temperature remains on the screen							
	2 = 'dEF' is viewed							
<b>dd</b>	Post-Defrost drip time		2	2	2	2	2	2
	0= No drip							

CAREL PARAMETERS		ISLAND FREEZER	WALL FREEZER	COMBI FREEZER	UPRIGHT FREEZER	COUNTER	MULTIDECK CABINET	
d7	defrost by-pass	0	0	0	0	0	0	
	0 = inactive ; 1 = active;							
d8	Alarm delay following defrost and door opening	30	30	30	30	30	30	
d9	Status of compressor protection times in hotgas bypass	1	1	1	1	1	1	
	0 = protection times are followed ; 1 = protection times are ignored							
Sd1	Defrost Probe value	-	-	-	-	-	-	
Sd2	Second Evaporator defrost probe value	-	-	-	-	-	-	
dC	Defrost time basis	0	0	0	0	0	0	
	0 = dl hour,dP1,dP2 and ddP minute; 1 = dl minute,Dp2 and ddP second							
d10	Time for defrost based on lamel temperature	0	0	0	0	0	0	
	0 = Function inactive							
d11	Temperature-based defrost activation temperature threshold	-30	-30	-30	-30	-30	-30	
d12	During Defrost, pressure transmitter alarm status	0	0	0	0	0	0	
	<b>probe failure</b>							<b>failure in supervisor</b>
	0 inactive							active
	1 active							active
	2 inactive							inactive
3 active	inactive							
dS1	Compressor stop time for successive defrost ( when stops for this time, defrost ends,	0	0	0	0	0	0	
	0 = Function inactive							
dS2	Compressor operation time for successive defrost (defrost starts when the	120	120	120	120	120	120	
ddt	Defrost end temperature offset for Power defrost	0.0	0.0	0.0	0.0	0.0	0.0	
ddp	Defrost time offset for Power defrost	0	0	0	0	0	0	
dn	Nominal Defrost bypass time rate	75	75	75	75	75	75	
d1S	daily defrost based on td1 time zone	0	0	0	0	0	0	
	0 = inactive							8 = 3 hours 0 minute
	1 = 24 hours 0 minute							9 = 2 hours 40 minutes
	2 = 12 hours 0 minute							10 = 2 hours 24 minutes
	3 = 8 hours 0 minute							11 = 2 hours 11 minutes
	4 = 6 hours 0 minute							12 = 2 hours 0 minute
	5 = 4 hours 48 minutes							13 = 1 hour 0 minute
	6 = 4 hours 0 minute							14 = 30 minutes
7 = 3 hours 26 minutes								

CAREL PARAMETERS		ISLAND FREEZER	WALL FREEZER	COMBI FREEZER	UPRIGHT FREEZER	COUNTER	MULTIDECK CABINET
<b>d2S</b>	see d1S parameter for td1 time zone daily defrosts	0	0	0	0	0	0
<b>dH1</b>	Pumpdown time	0	0	0	0	0	0
	0= pump down inactive						
<b>dHG</b>	Multiplied hot gas bypass type	0	0	0	0	0	0
	0 = Compensator valve is OFF usually						
	1 = Compensator valve is ON usually						
<b>ALM (Alarm)</b>							
<b>AA</b>	Determination of temperature probe for AH and AL alarms		1	1	1	1	1
	1 = control (sreg)	8 = auxiliary defrost probe (Sd2)					
	2 = virtual (Sv)	9 = auxiliary probe (Saux)					
	3 = blow (Sm)	10 = auxiliary probe 2 (Saux2)					
	4 = defrost (Sd)	11 = ortam sıcaklığı (SA)					
	5 = suction (Sr)	12 = ortam nemi (SU)					
	6 = superheat temperature probe(tGS)	13 = cam sıcaklığı (Syt)					
	7 =SH pressure transmitter temperature equivalence (tEu)	14 = çığırma noktası (SdP)					
<b>AA2</b>	Determination of temperature probe for AH2 and AL2 alarms control AA parameter		5	5	5	5	5
<b>A0</b>	Low and high temperature alarm difference		2.0	2.0	2.0	2.0	2.0
<b>A1</b>	Threshold type for AL and AH 1. Alarm delays		0	0	0	0	0
	0 = relative AL and AH set value 1 = absolute AL and AH absolute values						
<b>A2</b>	Threshold type for AL2 and AH2 2. Alarm delays		0	0	0	0	0
	0 = relative AL and AH set value 1 = absolute AL and AH finite values						
<b>AL</b>	Low temperature 1. alarm threshold		4	4	4	4	4
<b>AH</b>	High temperature 1. alarm threshold		5	5	5	5	5
<b>AL2</b>	Low temperature 2. alarm threshold		0	0	0	0	0
<b>AH2</b>	High Temperature 2. alarm threshold		0	0	0	0	0
<b>Ad</b>	Low and high temperature alarm alarm delay		15	15	15	15	15
<b>A4</b>	ID1 digital input configuration in S4 input		0	0	0	0	0
	0 = input is not active	5 = kapı switchi konfigürasyonu kompresör ve fanlar OFF					
	1 = momentary external alarm	6 = uzaktan ON/OFF					
	2 = delayed external alarm	7 = perde switchi					
	3 = defrost activation	8 = sürekli çevrim başlama / durma					
	4 = defrost starting	9 = ışık sensörü					

CAREL PARAMETERS		ISLAND FREEZER	WALL FREEZER	COMBI FREEZER	UPRIGHT FREEZER	COUNTER	MULTIDECK CABINET	
A5	ID2 digital input configuration in S5 input, see the list in A4 parameter	0	0	0	0	0	0	
A6	In the event of external alarm, solenoid/compressor working times. Compressor and solenoid work for this time, stop for 15 minutes and work againn.	0	0	0	0	0	0	
	0 = Compressor/valve always OFF; 100 = compressor/valve always ON							
A7	Time delay for delayed external alarm	0	0	0	0	0	0	
A8	Virtual digital input configuration see the list in A4 parameter	0	0	0	0	0	0	
A09	Digital input selection transferred from master to slave	0	0	0	0	0	0	
	0 = supervisor							3 = D13
	1 = D11							4 = D14
	2 = D12							5 = D15
A10	ID3 digital input configuration in S6 input see the list in A4 parameter	0	0	0	0	0	0	
A11	Id4 digital input configuration in S7 input, see the list in A4 parameter	0	0	0	0	0	0	
A12	Digital input configuration in D15 input, see the list in A4 parameter	0	0	0	0	0	0	
Ar	Is alarm signal in slaves shown in master?	1	1	1	1	1	1	
	0 = no ; 1 = yes							
A13	When slaves are offline, hotgas bypass procedure	0	0	0	0	0	0	
	0 = inactive 1 = active							
<b>Fan (Evaporator fans)</b>								
F0	Evaporator fan management	0	0	0	0	0	0	
	0 = always ON							
	1 = Fan activation Sd defrost - Sv virtual (or Sd defrost - Sm blow double thermostat control) 2 =Activation Sd defrost probe							
F1	Fan activation threshold (only F0=1 and 2)	-5.0	-5.0	-5.0	-5.0	-5.0	-5.0	
F2	Will fans stop when the compressor stops?	0	0	0	0	0	0	
	0 =Fans work 1 = Fans stop							
F3	Status of fans during defrost	0	0	1	1	0	0	
	0 = Fans work in Defrost 1 = fans stop							
Fd	Post-defrost drip fan waiting time	2	2	2	2	2	2	
Frd	Fan activation difference ( including variable speed fans)	2.0	2.0	2.0	2.0	2.0	2.0	
F5	Evaporator fan stop threshold (difference 1C)	50.0	50.0	50.0	50.0	50.0	50.0	
F6	Maximum Evaporator fan speed	100	100	100	100	100	100	

CAREL PARAMETERS		ISLAND FREEZER	WALL FREEZER	COMBI FREEZER	UPRIGHT FREEZER	COUNTER	MULTIDECK CABINET
F7	Minimum Evaporator fan speed	0	0	0	0	0	0
F8	Evaporator fan peak time	0	0	0	0	0	0
	0 = Function inactive						
F9	PWM1/' fan control output selection (by phase-break)	1	1	1	1	1	1
	0 = pulse 1 = time-dependant						
F10	Time of working of evaporator fans at maximum speed	0	0	0	0	0	0
	0 = Function inactive						
<b>Eud (Electronic valve)</b>							
P1	Electronic valve	2	2	2	2	2	2
	0 = not used 1 = PWM valve 2 = CAREL E2V valve						
P3	Superheat Set point	10.0	10.0	10.0	10.0	10.0	10.0
P4	Proportional rate	15.0	15.0	15.0	15.0	15.0	15.0
P5	Integration rate ( Integral factor)	150	150	150	150	150	150
	0 = Function inactive						
P6	Derivative rate	5.0	5.0	5.0	5.0	5.0	5.0
	0 = Function inactive						
P7	LowSH: low superheat threshold	7.0	7.0	7.0	7.0	7.0	7.0
P8	LowSH: low superheat integral time	15.0	15.0	15.0	15.0	15.0	15.0
	0 = Function inactive						
P9	LowSH: düşük superheat alarm gecikmesi	600	600	600	600	600	600
	0 = alarm inactive						
P10	Will solenoid valve be OFF in the event of low superheat or low suction temperature?	0	0	0	0	0	0
	1 = OFF is active						
P11	LSA: low evaporation temperature alarm	-45.0	-45.0	-45.0	-45.0	-45.0	-45.0
P12	LSA: alarm delay	600	600	600	600	600	600
	0 = alarm inactive						
P13	LSA: alarm difference (C)	10.0	10.0	10.0	10.0	10.0	10.0
	0 = reset the alarm all the time automatically						
P14	('blo') alarm signal activation	1	1	1	1	1	1
	1= blo alarm is active						
P15	Complementary temperature acceptance value in the event of Superheat pressure	-30	-30	-30	-12	-12	-12

CAREL PARAMETERS			ISLAND FREEZER	WALL FREEZER	COMBI FREEZER	UPRIGHT FREEZER	COUNTER	MULTIDECK CABINET
PH	Gas type		3	3	3	3	3	3
	1 = R22	8 = R600						
	2 = R134a	9 = R600a						
	3 = R404A	10 = R717						
	4 = R407C	11 = R744						
	5 = R410A	12 = R728						
	6 = R507A	13 = R1270						
	7 = R290	14 = R417A						
OSH	Superheat offset for modulation thermostate		0.0	0.0	0.0	0.0	0.0	0.0
	0 = Function inactive							
Phr	Fast updating of valve parameters by the supervisor		0	0	0	0	0	0
	0 = fast update is inactive							
PM1	MOP: Maximum evaporation pressure temperature value		50.0	50.0	50.0	50.0	50.0	50.0
PM2	MOP: Integral time		10.0	10.0	10.0	10.0	10.0	10.0
PM3	MOP: alarm delay		0	0	0	0	0	0
	0 = Function is inactive							
PM4	MOP: MOP function delay at the beginning		2	2	2	2	2	2
PM5	MOP: activating solenoid valve shutting		0	0	0	0	0	0
	0 = OFF is inactive							
	1 = OFF is active							
PL1	LOP: Minimum evaporation pressure temperature value		-50.0	-50.0	-50.0	-50.0	-50.0	-50.0
PL2	LOP: Integral time		0.0	0.0	0.0	0.0	0.0	0.0
PL3	LOP: alarm delay		0	0	0	0	0	0
	0 = Function is inactive							
SH	Superheat value		-	-	-	-	-	-
PPU	valve ON rate		-	-	-	-	-	-
tGS	Superheat temperature sensor reading value		-	-	-	-	-	-
tEu	Superheat pressure sensor temperature value (value of the pressure equivalent to the temperature)		-	-	-	-	-	-
/cE	Saturated evaporation temperature calibration		0.0	0.0	0.0	0.0	0.0	0.0
Po6	PWM expansion valve T on/OFF period		6	6	6	6	6	6
cP1	Valve position when the control is ON		30	30	30	30	30	30
Pdd	Post-Defrost valve position		10	10	10	10	10	10
PSb	valve standby position		0	0	0	0	0	0
PF	valve opening stages		-	-	-	-	-	-



CAREL PARAMETERS		ISLAND FREEZER	WALL FREEZER	COMBI FREEZER	UPRIGHT FREEZER	COUNTER	MULTIDECK CABINET	
PMP	Electronic expansion valve manual operation activation	0	0	0	0	0	0	
	0 = inactive 1 = active							
PMu	Manual valve position	-	-	-	-	-	-	
Phc	Large capacity valve activation	0	0	0	0	0	0	
<b>Cnf ( Configuration)</b>								
In	MPXPRO Unit type	1	1	1	1	1	1	
	0 = Slave 1 = Master							
Sn	Number of slave in local network	0	0	0	0	0	0	
	0 = No Slave							
H0	Supervisor and Master-Slave network address	199	199	199	199	199	199	
H1	AUX1 output configuration	8	8	8	8	8	8	
	0 = no function							7 = second Evaporator defrost output
	1 = alarm without energy normally							8 = Evaporator Fan output
	2 = energy alarm normally							9 = Glass heater output
	3 = auxiliary output							10 = Suction valve
	4 = auxiliary output shared by Master with slaves							11 = Compensation valve
	5 = Light output							12 = Solenoid valve
6 = auxiliary output shared by Master with slaves								
H2	Button set and remote control deactivation	1	1	1	1	1	1	
	1 = Button set and remote control is active							
H3	Remote control activation code	0	0	0	0	0	0	
	0 =no remote control activation code							
H4	Buzzer activation	0	0	0	0	0	0	
	0 = active; 1 = inactive							
H5	Please see AUX2 output configuration H1 parameter	7	2	2	2	2	2	
H6	Terminal button set locking configuration	0	0	0	0	0	0	
H7	Please see AUX3 output configuration H1 parameter	5	5	5	5	5	5	
H8	Output association with time bands	0	0	0	0	0	0	
	0 = Light 1 = AUX							

CAREL PARAMETERS		ISLAND FREEZER	WALL FREEZER	COMBI FREEZER	UPRIGHT FREEZER	COUNTER	MULTIDECK CABINET
H9	Output association with AUX button	0	0	0	0	0	0
	0 = Light 1 = AUX						
H10	Compressor output configuration	0	0	0	0	0	0
	0 = Cooling 1 = heating						
H11	Fan output configuration	0	0	0	0	0	0
	0 = Cooling 1 = Heating						
H12	Light sensor threshold	25	25	25	25	25	25
H13	Please see AUX4 output configuration H1 parameter	12	12	12	12	12	12
Hdn	default set parameters number	0	0	0	0	0	0
Htc	External time card insertion	0	0	0	0	0	0
	0 = not inserted						
rHu	Manual glass heater activation rate (rHt period)	70	70	70	70	70	70
	0 = Function is inactive						
rHt	Manual glass heater activation period	5	5	5	5	5	5
	0 = Function is inactive						
rHo	Glass heater modulation offset	2.0	2.0	2.0	2.0	2.0	2.0
rHd	Glass heater modulation difference	0.0	0.0	0.0	0.0	0.0	0.0
rHL	PWM output load type for glass heater modulation	0	0	0	0	0	0
	0 = resistant 1 = inductive						
rHA	Factor A for calculated glass temperature	2	2	2	2	2	2
rHb	Factor B for calculated glass temperature	22	22	22	22	22	22
<b>HSt (Alarm log)</b>							
HSO to 9	0 dan 9'a alarmlar (sete basin)	-	-	-	-	-	-
---	0 dan 9'a alarm kodu	-	-	-	-	-	-
h_	0 dan 9'a alarm houri	0	0	0	0	0	0
n_	0 dan 9'a alarm minutesi	0	0	0	0	0	0
---	0 dan 9'a alarm süresi	0	0	0	0	0	0
<b>HcP (HACCP alarms)</b>							
Ht0	HACCP alarm	0	0	0	0	0	0
HAn	HA alarm type number	0	0	0	0	0	0

CAREL PARAMETERS		ISLAND FREEZER	WALL FREEZER	COMBI FREEZER	UPRIGHT FREEZER	COUNTER	MULTIDECK CABINET
<b>HA to HA2</b>	HA type active HACCP alarm number	-	-	-	-	-	-
<b>y_</b>	From 1 to 3 alarm-Year	0	0	0	0	0	0
<b>M_</b>	From 1 to 3 alarm - month	0	0	0	0	0	0
<b>d_</b>	From 1 to 3 alarm - which day of the month	0	0	0	0	0	0
<b>h_</b>	From 1 to 3 alarm - hour	0	0	0	0	0	0
<b>n_</b>	From 1 to 3 alarm - minute	0	0	0	0	0	0
<b>...</b>	From 1 to 3 alarm - Alarm time	0	0	0	0	0	0
<b>HFn</b>	HF alarm type number	0	0	0	0	0	0
<b>HF to HF2</b>	HF type active HACCP alarm number	-	-	-	-	-	-
<b>y_</b>	From 1 to 3 alarm - Year	0	0	0	0	0	0
<b>M_</b>	From 1 to 3 alarm -month	0	0	0	0	0	0
<b>d_</b>	From 1 to 3 alarm - which day of the month	0	0	0	0	0	0
<b>h_</b>	From 1 to 3 alarm - hour	0	0	0	0	0	0
<b>n_</b>	From 1 to 3 alarm - minute	0	0	0	0	0	0
<b>_</b>	From 1 to 3 alarm - Alarm time	0	0	0	0	0	0
<b>Htd</b>	HACCP alarm delay	0	0	0	0	0	0
	0 = alarm viewing deactivated						
<b>rtc (Real Time Clock)</b>							
<b>td1 to 8</b>	Defrost time from 1 to 8 (press Set)	-	-	-	-	-	-
<b>d_</b>	From 1 to 8 defrost day selection	0	0	0	0	0	0
	0 = no defrost						
	1 to 7 = days one by one from Monday to Sunday						
	8 = every day from Monday to Friday						
	9 = everyday from Monday to Saturday						
	10 = only Saturday Sunday						
11 = everyday							
<b>h_</b>	Defrost hour	0	0	0	0	0	0
<b>n_</b>	Defrost minute	0	0	0	0	0	0
<b>P_</b>	Power defrost selection	0	0	0	0	0	0
	0 = Normal defrost; 1 =Power defrost						
<b>tS1 to 8</b>	Time band starting from 1 to 8 (press Set)	-	-	-	-	-	-
<b>d</b>	Time band starting: day	0	0	0	0	0	0
<b>h</b>	Time band starting: hour	0	0	0	0	0	0
<b>n</b>	Time band starting: minute	0	0	0	0	0	0
<b>tE1 to 8</b>	Time band end from 1 to 8 (press Set)	-	-	-	-	-	-



DANFOSS PARAMETERS		ISLAND FREEZER	WALL FREEZER	COMBI FREEZER	UPRIGHT FREEZER	COUNTER	MULTIDECK CABINET
<b>Normal operation</b>							
---	Temperature (setpoint)	-26	-20	-20	-20	0	2
<b>Thermostat</b>							
r01	Differential	2	2	2	2	2	2
r02	Max. limitation of setpoint setting	-22	-18	-18	-18	-4	-4
r03	Min. limitation of setpoint setting	-29	-23	-23	-23	4	4
r04	Adjustment of temperature indication	0	0	0	0	0	0
r05	Temperature unit (°C/°F)	0	0	0	0	0	0
r09	Correction of the signal from S4	0	0	0	0	0	0
r10	Correction of the signal from S3	0	0	0	0	0	0
r12	Manual service, stop regulation, start regulation (-1, 0, 1)	1	1	1	1	1	1
r13	Displacement of reference during night operation	0	0	0	0	0	0
r14	Define thermostat function	1	1	1	1	1	1
	1=ON/OFF						
	2=Modulating						
r15	Definition and weighting, if applicable, of thermostat sensors - S4% (100%=S4, 0%=S3)	100	0	0	0	50	50
r16	Time between melt periods	0	0	0	0	0	0
r17	Duration of melt periods	0	0	0	0	0	0
r21	Temperature setting for thermostat band 2 . As differential use r01	-26	-20	-20	-22	0	0
r59	Correction of the signal from S6	0	0	0	0	0	0
r61	Definition and weighting, if applicable, of thermostat sensors when night cover is on. (100%=S4, 0%=S3)	100	0	0	0	50	50
r62	Heat function	2	2	2	2	2	2
	Neutral zone between refrigeration and heat function						
r63	Time delay at switch between refrigeration and heat function	0	0	0	0	0	0
<b>Alarms</b>							
A03	Delay for temperature alarm	15	15	15	15	20	20
A04	Delay for door alarm	0	0	0	0	0	0
A12	Delay for temperature alarm after defrost	60	60	60	60	60	60
A13	High alarm limit for thermostat 1	-18	-15	-15	-15	4	6
A14	Low alarm limit for thermostat 1	-30	-26	-26	-26	-6	-6
A20	High alarm limit for thermostat 2	-18	-15	-15	-15	4	6
A21	Low alarm limit for thermostat 2	-30	-26	-26	-26	-6	-6
A22	High alarm limit for sensor S6 at thermostat 1	8	8	8	8	8	8
A23	Low alarm limit for sensor S6 at thermostat 1	-30	-30	-30	-30	-30	-30
A24	High alarm limit for sensor S6 at thermostat 2	8	8	8	8	8	8
A25	Low alarm limit for sensor S6 at thermostat 2	-30	-30	-30	-30	-30	-30

DANFOSS PARAMETERS		ISLAND FREEZER	WALL FREEZER	COMBI FREEZER	UPRIGHT FREEZER	COUNTER	MULTIDECK CABINET
A26	S6 alarm time delay	240	240	240	240	240	240
	With setting = 240 the S6 alarm will be omitted						
A27	Alarm time delay or signal on the DI1 input	30	30	30	30	30	30
A28	Alarm time delay or signal on the DI2 input	30	30	30	30	30	30
A36	Signal for alarm thermostat. S4% (100%=S4, 0%=S3)	100	0	0	0	50	50
A52	Delay for S6 (product sensor alarm) after defrost	90	90	90	90	90	90
<b>Compressor</b>							
c01	Min. ON-time	0	0	0	0	0	0
c02	Min. OFF-time	0	0	0	0	0	0
c05	Time delay for cutin of comp.2	5	5	5	5	5	5
<b>Defrost</b>							
d01	Defrost method	1	1	1	1	1	1
	0=off						
	1= EL						
	2= gAs						
d02	Defrost stop temperature	10	10	12	12	10	10
d03	Interval between defrost starts	8	8	6	6	6	6
d04	Max. defrost duration	35	35	35	35	45	45
d05	Displacement of time on cutin of defrost at start-up	0	0	0	0	0	0
d06	Drip off time	2	2	2	2	3	3
d07	Delay for fan start after defrost	2	2	2	2	0	0
d08	Fan start temperature	-5	-5	-5	-5	-5	-5
d09	Fan cutin during defrost	1	1	0	0	1	1
	0: Stopped						
	1: Running						
	2: Running during pump down and defrost						
d10	Defrost sensor	3	1	1	1	1	1
	0 =Stop on time						
	1=S5						
	2=S4						
	3=Sx						
(Application 1-8 and 10: both S5 and S6. Application 9: S5 and S5B)							
d16	Pump down delay	0	0	0	0	0	0
d17	Drain delay (used at hot gas defrost only)	0	0	0	0	0	0
d18	Max. aggregate refrigeration time between two defrosts	0	0	0	0	0	0
d20	Heat in drip tray. Time from defrosting stops to heating in the drip tray is switched off	30	30	30	30	30	30



DANFOSS PARAMETERS		ISLAND FREEZER	WALL FREEZER	COMBI FREEZER	UPRIGHT FREEZER	COUNTER	MULTIDECK CABINET	
t45	Clock - Setting of date	REAL TIME	REAL TIME	REAL TIME	REAL TIME	REAL TIME	REAL TIME	
t46	Clock - Setting of month	REAL TIME	REAL TIME	REAL TIME	REAL TIME	REAL TIME	REAL TIME	
t47	Clock - Setting of year	REAL TIME	REAL TIME	REAL TIME	REAL TIME	REAL TIME	REAL TIME	
<b>Miscellaneous</b>								
o01	Delay of output signals after start-up	5	5	5	5	5	5	
o02	Input signal on DI1. Function:	0	0	0	0	0	0	
	0=not used							7=thermostat band changeover (activate r21)
	1=status on DI1							8=alarm function when closed
	2=door function with alarm when open							9=alarm function when open
	3=door alarm when open							10=Appliance cleaning (pulse signal)
	4=defrost start (pulse-signal)							11=forced cooling at hot gas defrost
	5=ext.main switch							12=night cover
6=night operation	15=case shut down							
o03	Network address	0	0	0	0	0	0	
o04	On/Off switch (Service Pin message) IMPORTANT! o61 <b>must</b> be set prior to o04 (used at LON 485 and DANBUSS only)	Off	Off	Off	Off	Off	Off	
o05	Access code 1 (all settings)	0	0	0	0	0	0	
o06	Used sensor type	0	0	0	0	0	0	
	0=Pt1000							
	1=Ptc1000,							
o08	Readout of software version	**	**	**	**	**	**	
o16	Max hold time after coordinated defrost	20	20	20	20	20	20	
o17	Select signal for display view. S4% (100%=S4, 0%=S3)	100	0	0	0	50	50	
o20	Pressure transmitter working range – min. value	-1	-1	-1	-1	-1	-1	
o21	Pressure transmitter working range – max. value	12	12	12	12	12	12	



DANFOSS PARAMETERS			ISLAND FREEZER	WALL FREEZER	COMBI FREEZER	UPRIGHT FREEZER	COUNTER	MULTIDECK CABINET	
o30	Refrigerant setting:		19	19	19	19	19	19	
	1=R12	15=R227							29=R1270
	2=R22	16=R401A							30=R417A
	3=R134a	17=R507							31=R422A
	4=R502	18=R402A							32=R413A
	5=R717	19=R404A							33=R422D
	6=R13	20=R407C							34=R427A
	7=R13b1	21=R407A							35=R438A
	8=R23	22=R407							36=R513A
	9=R500	23=R410A							37=R407F
	10=R503	24=R170							38=R1234ze
	11=R11	25=R290							39=R1234yf
	12=R142b	26=R600							40=R448A
	13=User defined	27=R600a							41=R449A
14=R32	28=R744	42=R452A							
o30	Refrigerant setting:		19	19	19	19	19	19	
o37	Input signal on DI2. Function:		0	0	0	0	0	0	
	(0=not used.	5=ext. main switch							10=Appliance cleaning (pulse signal).
	1=status on DI2.	6=night operation							11=forced cooling at hot gas defrost.).
	2=door function with alarm when open.	7=thermostat band changeover (activate r21).							12=night cover,
	3=door alarm when open.	8=alarm function when closed.							13=coordinated defrost).
4=defrost start (pulse-signal).	9=alarm function when open.	15=case shut down							
o38	Configuration of light function:		1	1	1	1	1	1	
	1=Light follows day /night operation,								
	2=Light control via data communication via 'o39',								
	3=Light control with a DI-input,								
4=As "2", but light switch on and night cover will open if the network cut out for more than 15 minutes.									
o39	Activation of light relay (only if o38=2) On=light		Off	Off	Off	Off	Off	Off	
o41	Rail heat On time during day operations		100	100	100	100	100	100	
o42	Rail heat On time during night operations		100	100	100	100	100	100	
o43	Rail heat period time (On time + Off time)		10	10	10	10	10	10	
o46	Appliance cleaning.		0	0	0	0	0	0	
	0=no Appliance cleaning.								
	1=Fans only.								
	2=All output Off.								
o61	Selection of EL diagram. See overview page 12 and 13		9	1	4	4	1	1	
o62	Download a set of predetermined settings. See overview page 27.		0	0	0	0	0	0	

DANFOSS PARAMETERS			ISLAND FREEZER	WALL FREEZER	COMBI FREEZER	UPRIGHT FREEZER	COUNTER	MULTIDECK CABINET	
o64	Access code 2 (partial access)		0	0	0	0	0	0	
o67	Replace the controllers factory settings with the present settings		Off	Off	Off	Off	Off	Off	
o84	Input signal on DI3. Function: (high voltage input)		0	0	0	0	0	0	
	(0=not used.	6=night operation,							12=night cover.
	1=status on DI2.	7=thermostat band changeover (activate r21)							13=Not used.
	2=door function with alarm when open.	8=Not used.							14=Refrigeration stopped (forced closing)).
	3=door alarm when open	9=Not used.							15=case shut down
	4=defrost start (pulse-signal).	10=Appliance cleaning (pulse signal).							
	5=ext. main switch	11=forced cooling at hot gas defrost,							
o85	Rail heat control		0	0	0	0	0	0	
	0=not used,								
	1=pulse control with timer function (o41 and o42),								
	2=pulse control with dew point function								
o86	Dew point value where the rail heat is minimum		8	8	8	8	8	8	
o87	Dew point value where the rail heat is 100% on		17	17	17	17	17	17	
o88	Lowest permitted rail heat effect in %		30	30	30	30	30	30	
o89	Time delay from "open door" refrigeration is started		30	30	30	30	30	30	
o90	Fan operation at stopped cooling (forced closing): 0= Stopped (defrost allowed)		1	1	1	1	1	1	
	1= Running (defrost allowed)								
	2= Stopped (defrost not allowed)								
	3= Running (defrost not allowed)								
o92	1=defrost stop temperature,		1	1	1	1	1	1	
	2=S6 temperature,								
	3=S5_B temperature (application 9), 4=S3B (application 10)								
o97	Display of temperature		1	1	1	1	1	1	
	1= u56 Air temperature								
	2= u36 product temperature								
o98	Light and night blinds defined		0	0	0	0	0	0	
	0: Light is switch off and night blind is open when the main switch is off								
	1: Light and night blind is independent of main switch								

DANFOSS PARAMETERS		ISLAND FREEZER	WALL FREEZER	COMBI FREEZER	UPRIGHT FREEZER	COUNTER	MULTIDECK CABINET
P41	Configuration of alarm relay	1	1	1	1	1	1
	The alarm relay will be activated upon an alarm signal from the following groups:						
	1 - High temperature alarms						
	2 - Low temperature alarms						
	4 - Sensor error						
	8 - Digital input enabled for alarm 16 - Defrosting alarms						
	32 - Miscellaneous 64 - Injection alarms						
The groups that are to activate the alarm relay must be set by using a numerical value which is the sum of the groups that must be activated. (E.g.: a value of 5 will activate all high temperature alarms and all sensor error and 0 will cancel the relay function).							